

PURUS CP

Near Pulseless and Compact

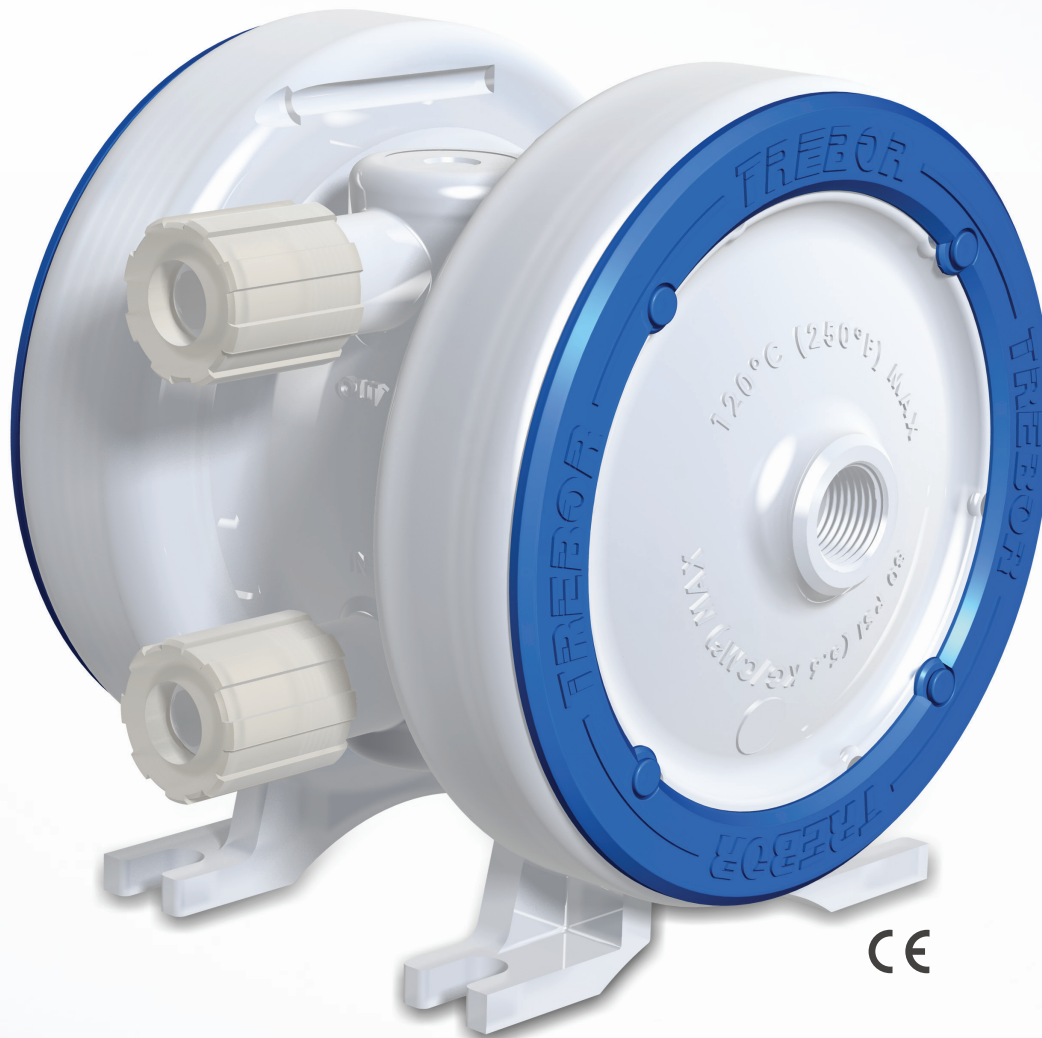

ALL PFA/PTFE
MATERIALS

CROSS-PHASE
DISCHARGE™

MOLDED
CONSTRUCTION

NO PUSH
PLATES

INTEGRATED
FLARE FITTINGS
(OTHER OPTIONS
AVAILABLE)

COMPACT
FOOTPRINT

The Purus CP is a two-chamber, cross phase discharge pump that minimizes fluctuations in pressure and flow. This pump is ideal for precision dispensing applications and for chemical slurry applications. It features a small, self-contained control systems, free of special power requirements, that enables easy integration into new and existing systems.

This is PURE INNOVATION.



MAX FLOW
6 LPM / 1.6 GPM



MAX TEMPERATURE
120 °C / 248 °F



MAX PRESSURE
60 PSI / .41 MPa



DRY SUCTION LIFT
11' / 3.4m

TREBOR

treborintl.com

Trebor International | North/South America +1 800 669 1303 | Europe +49 9120 1804-65 | Asia +65 6684 7319

A Unit of IDEX Corporation

FLOW PERFORMANCE

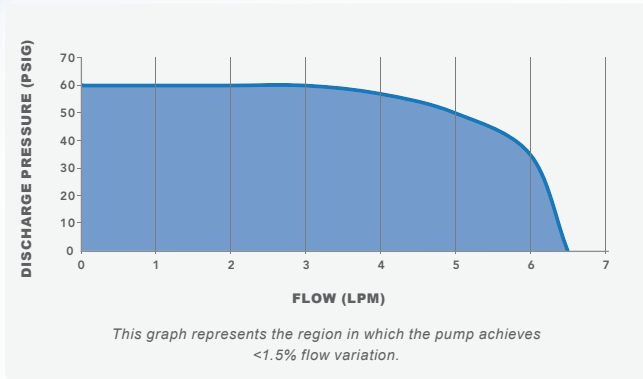

CPM VS. FLOW REQUIRED

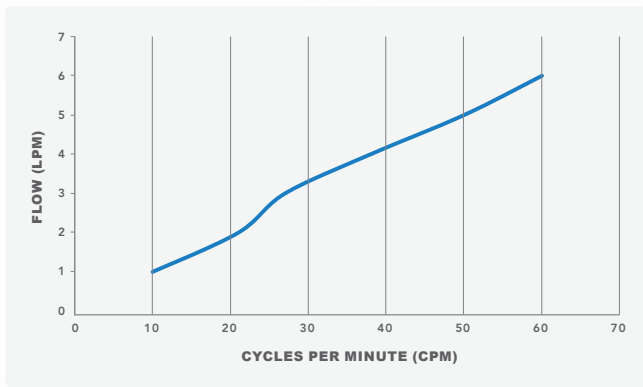

PUMP OPTIONS

PUMP	PCPF00	Purus CP, PFA
FLUID FITTINGS	0	1/2" Flare
	1	1/2" Pillar Super 300
OPTIONS	A0	No Option

Example of an order number based on configuration options:

PCPF00 1 A0

Compatible with our PC15 Controller

DIMENSIONS IN MILLIMETERS (IN.)

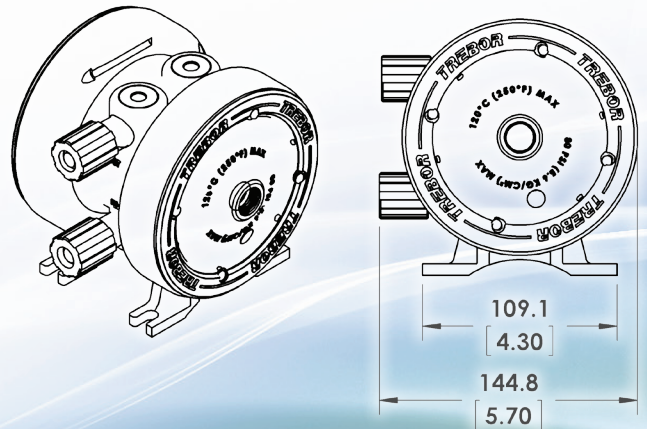
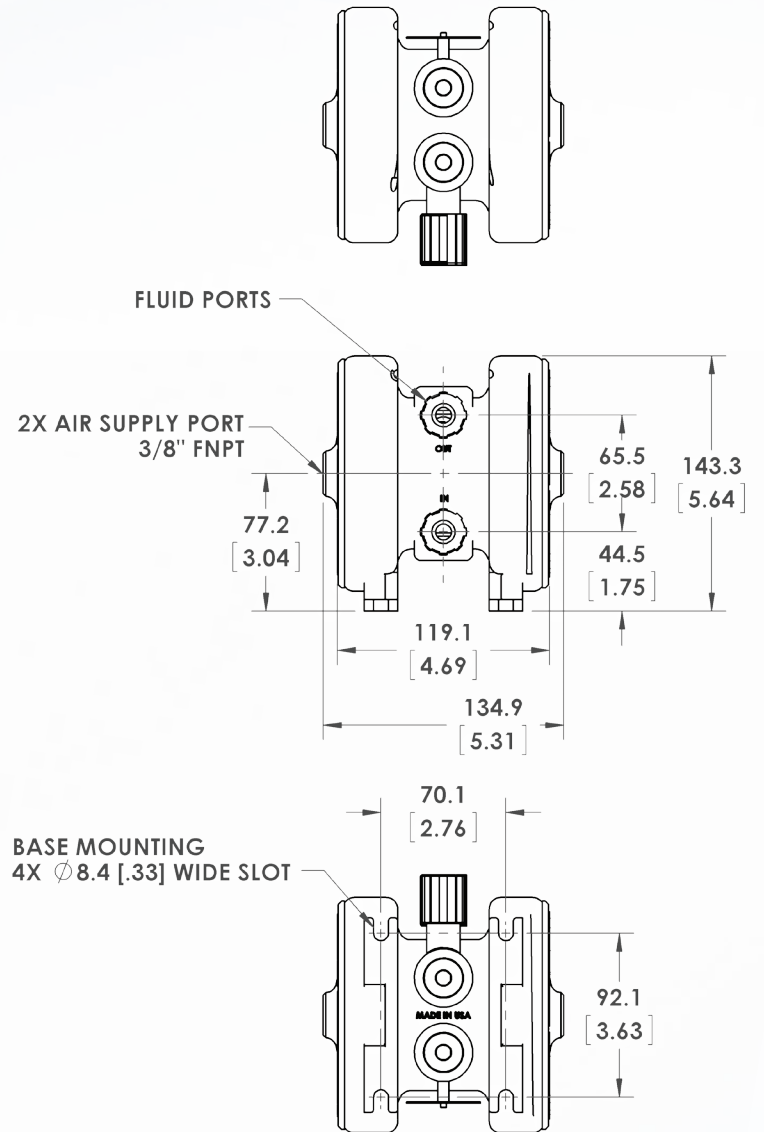

Trebor uses virgin PTFE and PFA in all products...no re-processed material is allowed.

Trebor International | North/South America +1 800 669 1303 | Europe +49 9120 1804-65 | Asia +65 6684 7319



treborintl.com

A Unit of IDEX Corporation