

Phone: 800-669-1303 or 801-561-0303
Fax: 801-255-2312
e-mail: treborservice@idexcorp.com

TREBOR
A Unit of IDEX Corporation

PURUS CP

Operation / Maintenance Manual

SERIAL NUMBER (located on top of product):

IDEX
IDEX CORPORATION

02/10/2016– MPCP-A

CONTENTS

1	INTRODUCTION.....	3
1.1	INTENDED USE AND AUDIENCE	4
2	SAFETY	5
2.1	SAFETY PRECAUTIONS	5
2.1.a	General Safety	5
3	INSTALLATION	6
3.1	UTILITIES / HOOK-UP	7
3.2	UNPACKING	7
3.3	ORIENTATION	7
3.4	FLUID CONNECTIONS.....	7
4	OPERATION.....	8
4.1	PRINCIPALS OF OPERATION	8
4.2	START UP	8
4.3	CONTROLLER.....	9
4.4	PERFORMANCE CHARTS	9
5	INSPECTION AND MAINTENANCE	11
5.1	MAINTENANCE.....	11
5.2	MATERIALS LIST	11
5.2.a	Wetted Materials.....	11
5.2.b	Non-wetted Materials.....	11
6	PC15CP (OPTIONAL) INSTALLATION	12
6.1	PC15CP OVERVIEW	12
6.2	PC15CP INSTALLATION	12
6.3	PC15CP UTILITIES / HOOK-UP	13
6.4	PC15CP CONTROLLER OPERATION.....	14
6.4.a	Turning Pump On and Off	14
7	TROUBLESHOOTING	15
7.1	PUMP.....	15
8	WARRANTY AND EXCLUSIONS	16
9	CONTACT INFORMATION	17
9.1	GENERAL CONTACT INFORMATION.....	17
9.2	TECHNICAL SUPPORT	17
9.3	REGIONAL REPRESENTATIVES	17

1 INTRODUCTION

Purus CP – A Revolutionary PFA High-Purity, Low-Pulsation Pump!

TREBOR'S Purus CP diaphragm pump offers a unique solution to critical applications requiring stable flow and low pulsation. With a revolutionary injection molded PFA design, Trebor has created an ultrapure pump utilizing proven components with minimal parts. This manufacturing approach has created a reliable, leak proof, disposable pump that costs less than most competitors' rebuild kits; while providing the utmost in purity and performance. The Purus CP is constructed entirely of PFA and PTFE, and includes no elastomers or metal parts for maximum purity and chemical compatibility.

Purus CP pumps are externally controlled and when combined with the Trebor PC15 Pump Controller can minimize pulsation to within 3% peak to peak.

Product Benefits:

- Maintains constant flow within 3% or less at flows from 0-6 lpm.
- Longer stroke for excellent suction lift and priming capability.
- Operating life exceeding 100 million cycles (most applications).
- 100% PFA/PTFE wetted construction for the ultimate chemical compatibility and process purity.
- No elastomer seals or gaskets to break down or replace.
- No metal parts to corrode or contaminate process.
- No maintenance.
- Compact size.
- Air operated.
- Handles chemical temperatures up to 120°C.
- FM4910 compliant.
- Cleaned, assembled, and packaged in Class 1000 clean room.

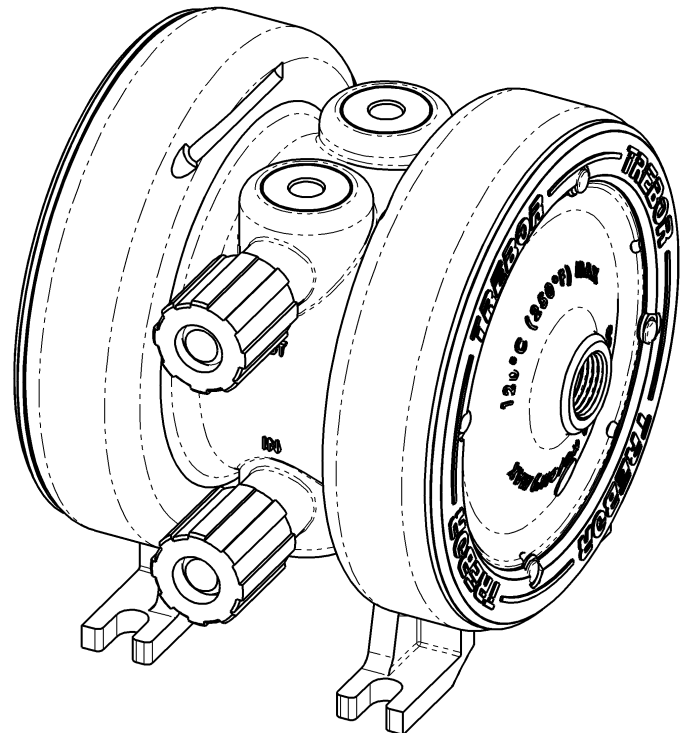

1.1 INTENDED USE AND AUDIENCE

The Purus CP pump is designed to safely pump liquids up to 120°C.

This manual only covers the Trebor Purus CP pump and pump accessories provided by Trebor.

The Purus CP pump is not to be used for purposes other than that which it is designed for. The pump and optional components are to be used only with liquids and parameters stated within this manual. This manual assumes personnel are familiar with the installation, operation and maintenance requirements of chemical pumps.

The Purus CP pump is intended for use by properly trained personnel. Read and understand this manual prior to installation and/or operation of the pump or pump controller. Do not use this equipment until familiar with its operation and features.

2 SAFETY

2.1 SAFETY PRECAUTIONS

This section provides important information for safe operation of the Purus CP pump.

The equipment described in this manual can be used to pump hazardous chemicals that can be dangerous. Local policies and procedures for safely operating any Trebor Purus CP pump(s) supersede the safety considerations listed below. It is the responsibility of all personnel to follow such policies and procedures. All safety guard devices must be in place when equipment is in operation. Operators, set-up operators, helpers or installation personnel should not alter, remove or disable safety devices or equipment.

2.1.a General Safety

- There are no serviceable parts inside the pump; never open or disassemble. Attempting to do so will render the pump inoperable and void the product warranty.
- Do not attempt to work on or with hazardous chemicals or electrical equipment without proper safety training and certification, understand first aid for electrical shock and hazardous chemicals spills.
- Lockout and tag the electrical and chemical systems prior to installation or replacement. Refer to company safety policies and procedures prior to installation or replacement.
- Always disengage the pump and optional equipment from electrical sources prior to installation or replacement.
- Always refer to company safety policies and procedures for flushing and decontamination prior to removal.



CAUTION: When handling potentially dangerous fluids under pressure, the pump and its fittings should be placed in an enclosure away from operators.

3 INSTALLATION

Ensure all system interlock and safety devices are functional prior to operation (refer to Section 2, Safety Requirements). Before starting the system, it is important to read and understand Section 4, Operation. Only trained, qualified, authorized personnel should operate this pump.

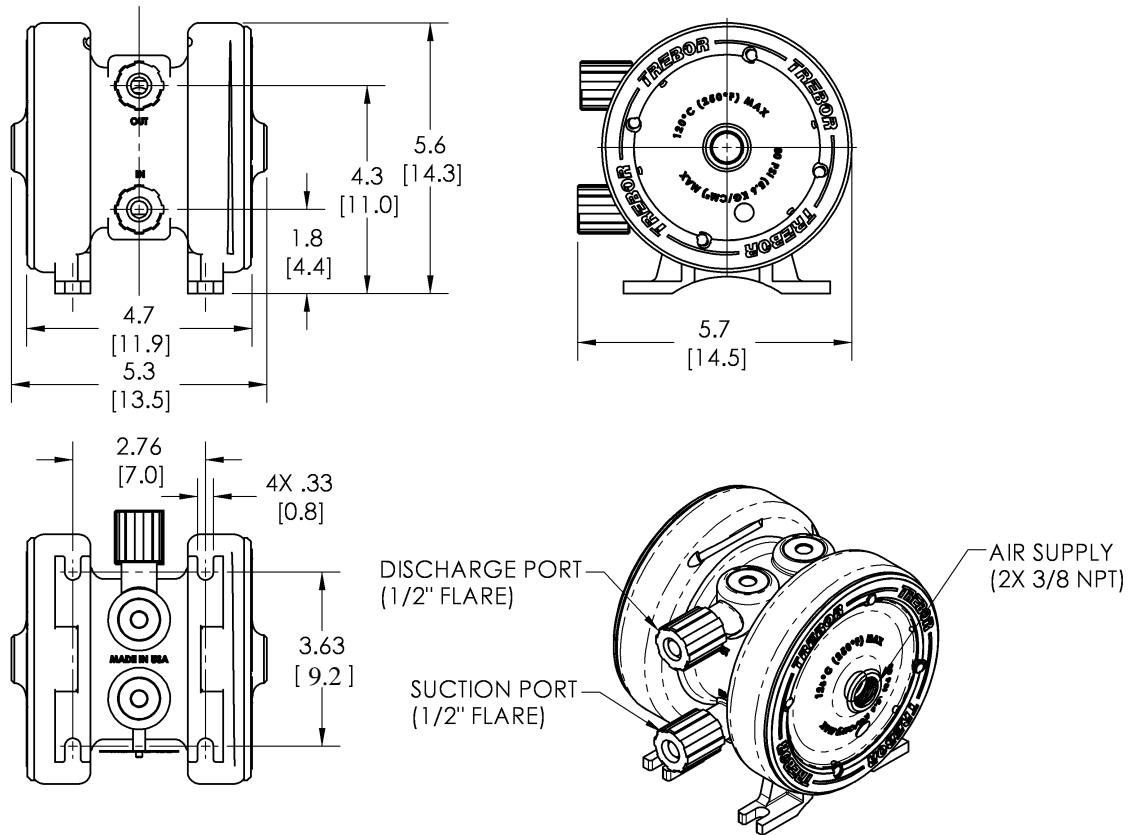

Figure 3-1: Dimensions (in / [cm])

3.1 UTILITIES / HOOK-UP

<u>Utility</u>	<u>Pump</u>
Air Inlet:	<ul style="list-style-type: none"> • 3/8" FNPT per head.
Air Supply:	<ul style="list-style-type: none"> • 20-80 PSIG (.14 – .55 MPa), clean dry air or inert gas
Fluid Ports:	<ul style="list-style-type: none"> • 1/2" Flare • 1/2" Tube Stub (Optional) • 1/2" Pillar Super 300 (Optional)
Pump Weight:	<ul style="list-style-type: none"> • 2.2 lbs (1.0 Kg) dry

3.2 UNPACKING

After unpacking, the pump should be checked for any damage that may have occurred during shipment. Damage should be reported to the carrier immediately.

The following items should be included within the shipping container:

<u>QTY.</u>	<u>DESCRIPTION</u>
1	Purus CP Pump
1	Purus CP Manual
1	Quick Installation Guide (QIG)

NOTE: Although extensive efforts are made to deliver pumps to our customers completely dry, new pumps may contain residual moisture from their final DI water test.

3.3 ORIENTATION

To maintain self-priming ability and pumping efficiency the pump should be positioned within 15° from level.

3.4 FLUID CONNECTIONS

- Attach the inlet and outlet fluid connections per the fitting manufacturer's specifications. Fluid connections are located on the pump side, inlet lower and outlet upper, see Figure 3-1.
- For high-temperature operation, Trebor recommends operating the pump with DI water for two or more thermal cycles to visually inspect for leaks prior to pumping chemicals.
- For maximum flow performance, the following is recommended
 - Maximize suction line diameter
 - Minimize suction line length
 - Minimize suction line restrictions (i.e. valves, fittings)

4 OPERATION

4.1 PRINCIPALS OF OPERATION

- The Purus CP accomplishes near pulseless flow by Cross-Phase operation (refer to the following step-by-step illustration):

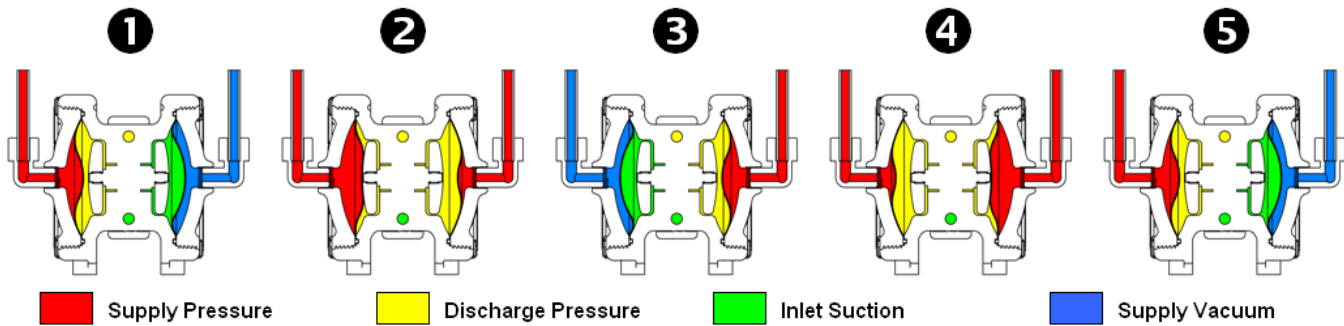

- ① Chamber 1 – pressure / Chamber 2 – vacuum.
- ② Chamber 1 – pressure / Chamber 2 – pressure (crossed-phase).
- ③ Chamber 1 – vacuum / Chamber 2 – pressure.
- ④ Chamber 1 – pressure / Chamber 2 – pressure (crossed-phase).
- ⑤ Chamber 1 – pressure / Chamber 2 – vacuum.

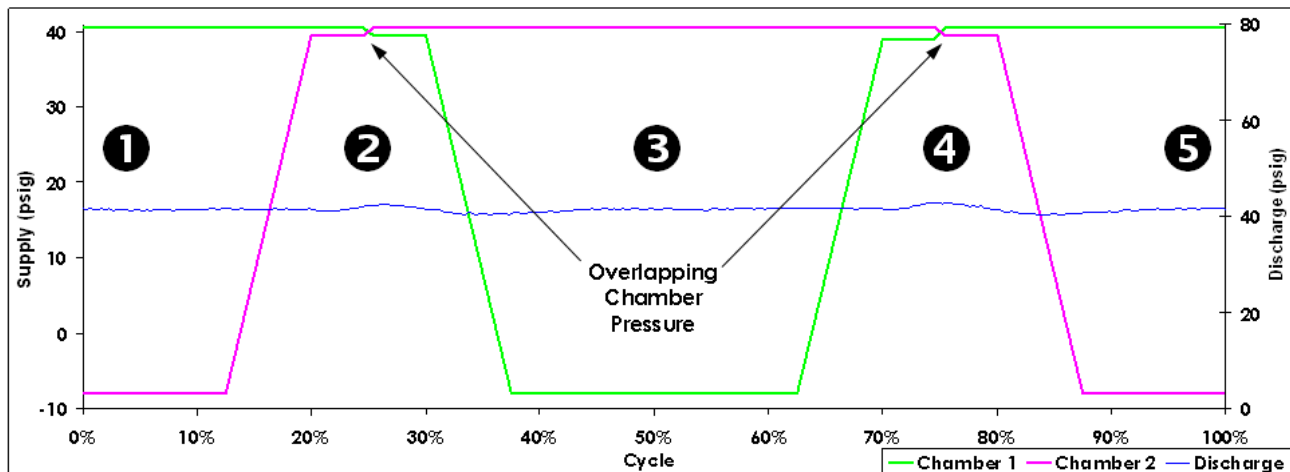

4.2 START UP

- Open the fluid suction (IN) line valve, if necessary
- Open the fluid discharge (OUT) line valve, if necessary
- Set air pump supply regulator at the desired discharge pressure. Increase pressure to attain desired outlet pressure, up to the maximum rating (See Section 3.1)
- Activate pump controller.

- Refer to Troubleshooting Section 7 if pump fails to start or contact Trebor for further assistance.

ATTENTION: The pump should be operated with clean, dry air or nitrogen. Particulate, water and oils in the air supply can damage or contaminate the pump air chamber.

NOTE: The Purus CP can be operated dry for extended periods up to 24 continuous hours.

4.3 CONTROLLER

- The Purus CP pump requires an external controller.
 - Trebor PC15CP

NOTE: See PC15CP manual for operating instructions, requirements, limitations, and troubleshooting.

4.4 PERFORMANCE CHARTS

Pumping capacity is a function of air supply pressure and volume, suction head, suction line restrictions, discharge head, discharge line restriction, and fluid specific gravity and viscosity.

The chart below defines the relationship between the pump controller cycle rate and the required flow from the Purus CP utilizing the PC15-02 controller.

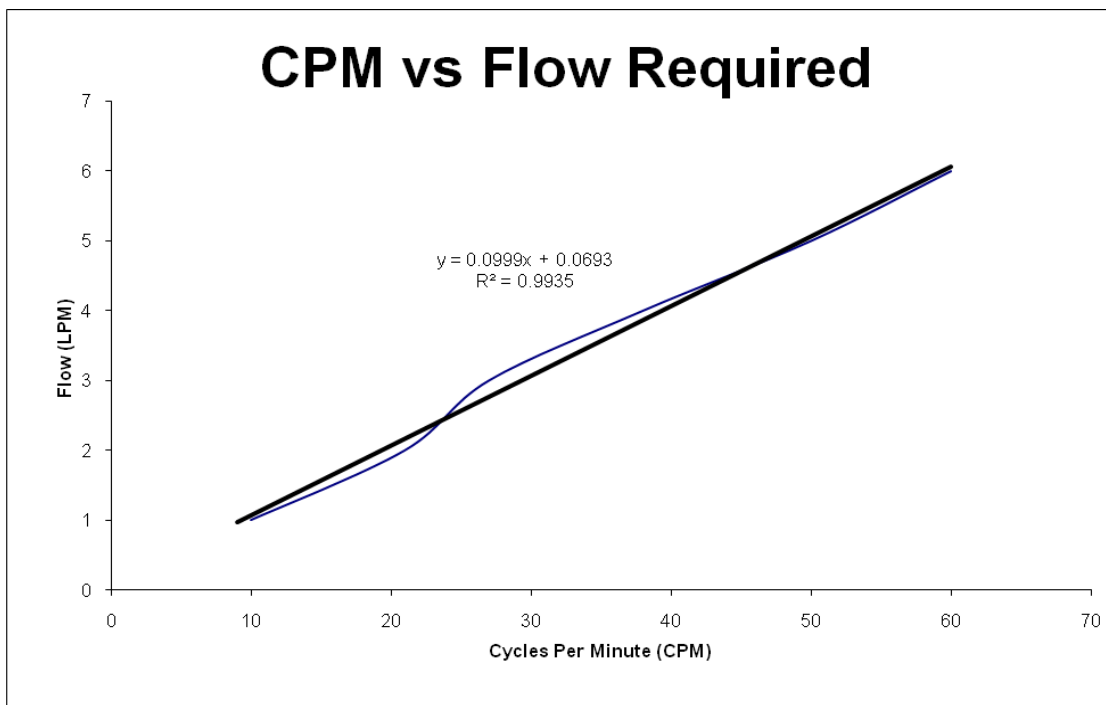

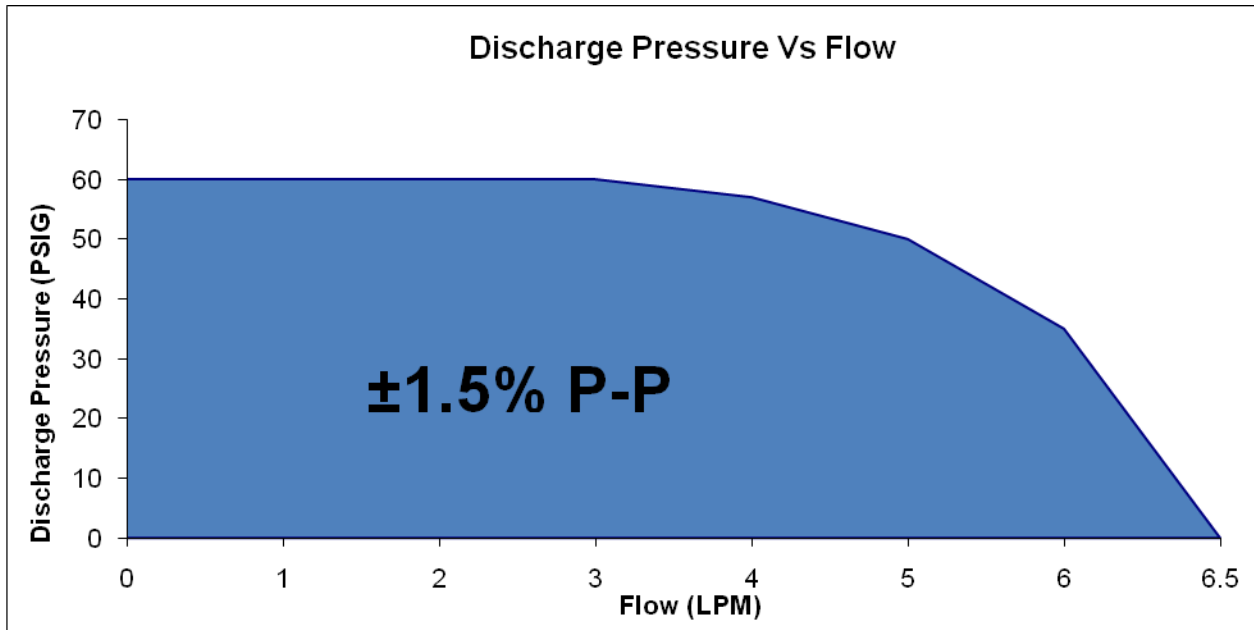

Figure 4-2: Pressure and Flow Capacity Chart

The preceding chart defines a region of operation over which the Purus CP pump may be operated with a PC15 pump controller with a discharge flow variance of less than +/-1.5% of nominal value.

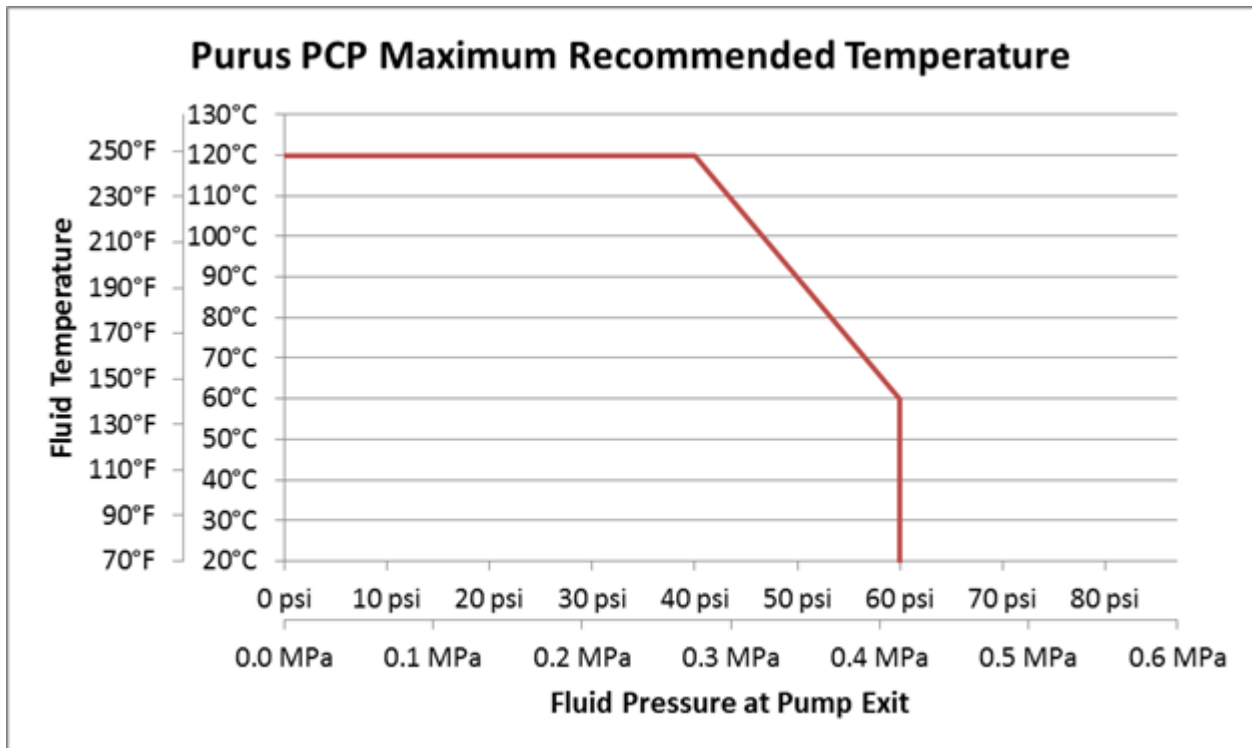

Figure 4-3: Purus CP Recommended Temperature Curve

5 INSPECTION AND MAINTENANCE

5.1 MAINTENANCE

The Purus CP has no serviceable parts. Pumps removed from service, decommissioned, or dismantled should be decontaminated and disposed of per company policy.

5.2 MATERIALS LIST

5.2.a Wetted Materials

- PFA and PTFE

5.2.b Non-wetted Materials

- PVDF and PP

NOTE: PURUS CP has no serviceable parts.

6 PC15 (OPTIONAL) INSTALLATION

6.1 PC15 OVERVIEW

The PC15 Pump Controller is designed specifically to operate Trebor's Purus CP pump. Cross-phase timing results in overlapping pump strokes which produces a near pulse-less pump output. PC15 controllers can be configured depending on flow requirements (See QIG manual)

6.2 PC15 INSTALLATION

The PC15 pump controller can be installed in any orientation. Pump controller mounts using four 1/4" (6mm) bolts and should be mounted above the level of the fluid feeding the pump. Allow clearance for tubing connectors.

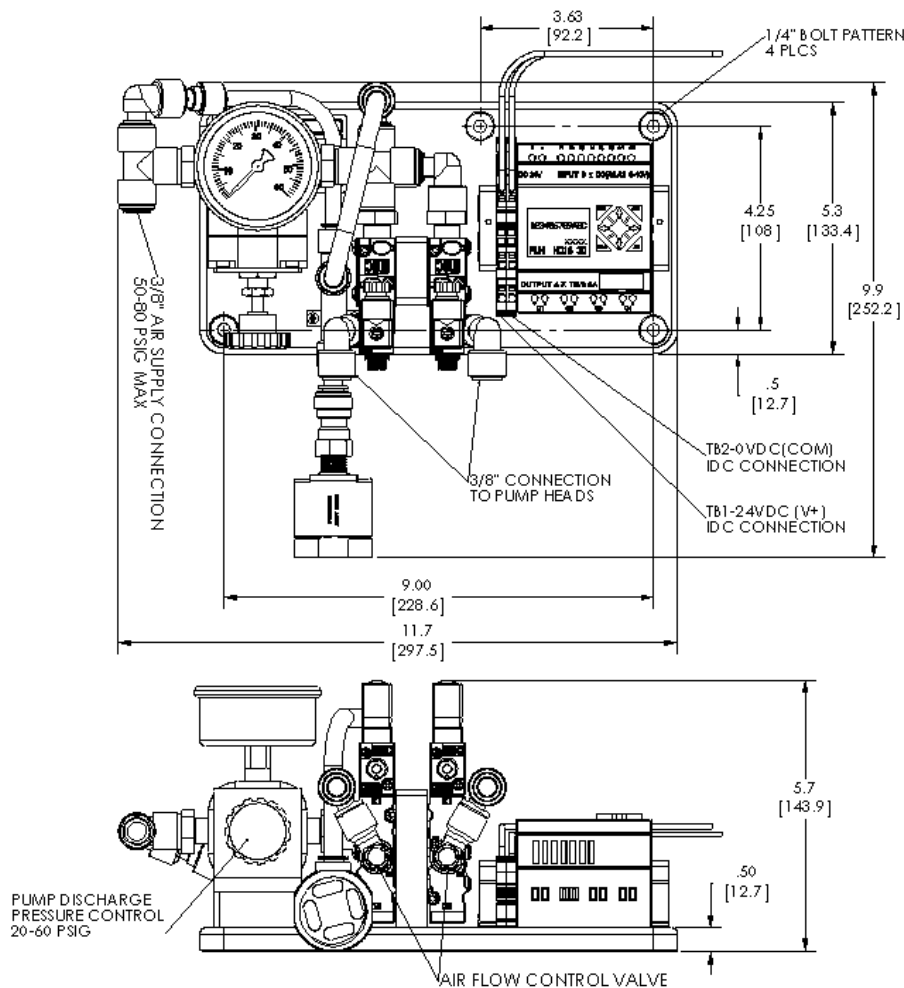

Figure 6-1 Dimension (in / [mm])

6.3 PC15 UTILITIES / HOOK-UP

<u>Utility</u>	<u>Pump</u>
Air Inlet:	<ul style="list-style-type: none"> • 3/8" Diameter supply tube.
Air Supply:	<ul style="list-style-type: none"> • 50-80 PSIG (.55±.03 MPa Max), clean dry air or inert gas
Power	<ul style="list-style-type: none"> • 24VDC - 500mA
Controller Weight:	<ul style="list-style-type: none"> • 4.4 lbs (2.0 Kg)

ATTENTION: Air supplied to the PC15 pump controller must be regulated to 50 - 80 PSIG to operate the vacuum venturi. An onboard precision regulator controls pump air supply pressure.

- Air supply connections between the pump and the pump controller are required.

NOTE: 3/8" tubing required for distances not to exceed 4 meters between the pump and the pump controller.

- 24VDC is required to operate the pump controller.
 - Terminal blocks are insulation displacement type. Insert 22-16 awg wires into the indicated location and rock lever to engage connection, see Figure 6-2.

NOTE: Follow local wiring codes and applicable wiring standards to insure proper power and over-current protection.

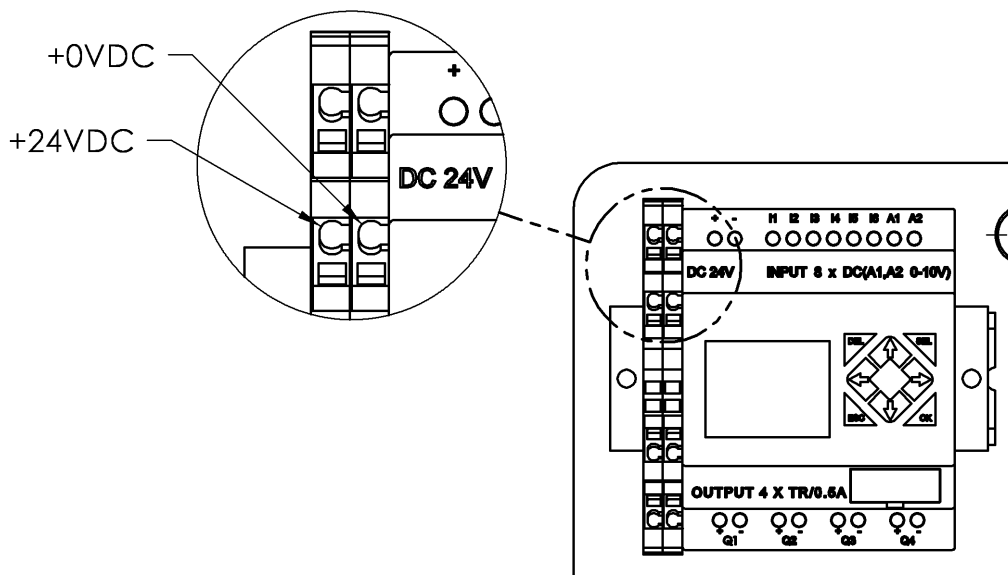

Figure 6-2: 24VDC Connection

6.4 PC15 CONTROLLER OPERATION

Ensure that all system interlock and safety devices are functional prior to operation. Before starting the system, it is important to read and understand the PC15PC manual. Only trained, qualified, authorized personnel should operate this pump controller.

The controller is operated by using the buttons located on the PLR, see Table 6-1.

Table 6-1: PLC Buttons

Button	Normal mode	Numeric value change mode (while digit is flashing)
←	Scroll through Menu pages.	Activates setup pages when depressed during Home page.
→	Enables/Disables controller cycling.	Activates controller when depressed during Home page.
↑	Increases pump cycle rate on Home page.	Increases value of digital readout.
↓	Decreases pump cycle rate on Home page.	Reduces value of digital readout.
SEL	Maintenance alarm page.	Displays the Maintenance alarm page
ESC	Return to home page	Displays the Home page.

6.4.a Turning Pump On and Off

From the Home Page, pressing the RIGHT arrow key (→) will start and stop the cycling of the pump controller. When activated a cursor will be located below position 3 (Figure 6-3), accompanied by an oscillating cursor between positions 1 & 2 (Figure 6-3).



Figure 6-3: Controller Off



Figure 6-4: Controller Cycling

NOTE: See PC15 manual for additional instructions, requirements, limitations and troubleshooting.

7 TROUBLESHOOTING

7.1 PUMP

SYMPTOM	CAUSES	SOLUTIONS
<ul style="list-style-type: none"> Bubbles in Fluid Discharge 	<ul style="list-style-type: none"> Diaphragm puncture 	<ul style="list-style-type: none"> Replace pump assy. (Non Serviceable)
	<ul style="list-style-type: none"> Loose inlet fitting 	<ul style="list-style-type: none"> Check and tighten all fittings on the suction line feeding the pump.
<ul style="list-style-type: none"> Fluid Leaks 	<ul style="list-style-type: none"> Weld failure 	<ul style="list-style-type: none"> Replace pump assembly (Non Serviceable)
	<ul style="list-style-type: none"> Loose suction or discharge connections 	<ul style="list-style-type: none"> Inspect tubing and tighten fluid fittings.

For controller troubleshooting guide refer to PC15 manual.

8 WARRANTY AND EXCLUSIONS



See the Trebor Standard Limited Warranty at

www.idex-hs.com/support/trebor/downloads/TreborStandardLimitedWarranty_02-07.pdf

9 CONTACT INFORMATION

9.1 GENERAL CONTACT INFORMATION

Web: www.teborintl.com
Phone Number: (801) 561-0303
Toll Free Number: (800) 669-1303
Fax Number: (801) 255-2312
Email: treborinfo@idexcorp.com
treborsales@idexcorp.com
Address: Trebor International
8100 South 1300 West
West Jordan, Utah 84088 U.S.A.

9.2 TECHNICAL SUPPORT

Email: treborservice@idexcorp.com
Phone Number: (801) 244-6156

9.3 REGIONAL REPRESENTATIVES

Web: www.treborintl.com/about_contact_us.asp#