

Mega 255 PUMP

Operation / Maintenance Manual

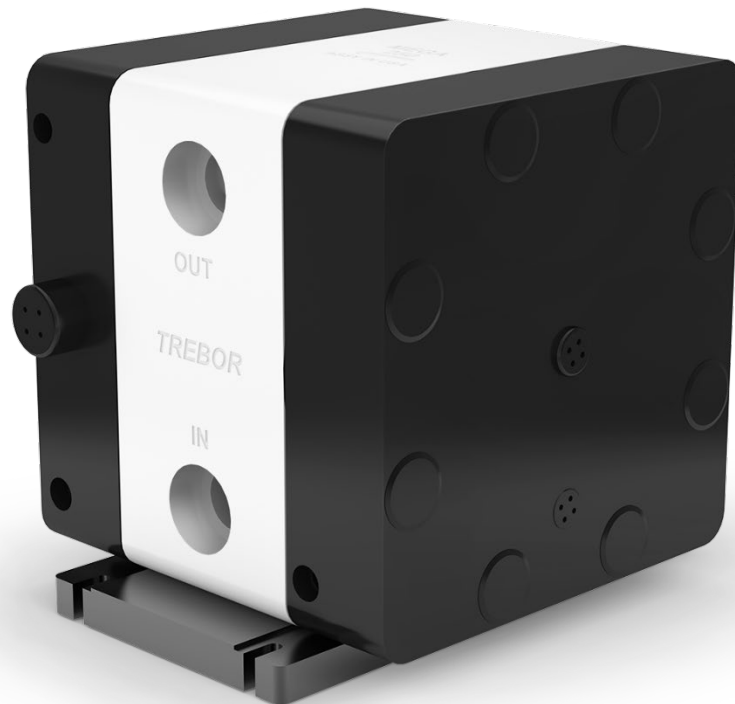

CONTENTS

1	INSTALLATION	3
1.1	UNPACKING	3
1.2	TIE BOLT TORQUE	3
1.3	UTILITIES / HOOK-UP	3
2	OPTIONS	5
2.1	FLUID PORT CONNECTION OPTIONS.....	5
2.2	FLUID FITTINGS / SURGE SUPPRESSOR HOOK-UP	5
2.3	OPTIONAL LEAK SENSING	6
2.3.a	Installation.....	6
3	START-UP	8
3.1	HIGH TEMPERATURE OPERATION	8
3.2	PERFORMANCE CHARTS	9
4	MAINTENANCE	11
4.1	PREVENTIVE MAINTENANCE SCHEDULE.....	11
4.1.a	Preventive Maintenance Record	13
4.2	RECOMMENDED SPARE PARTS	14
4.3	TOOLS.....	15
4.4	PARTS ILLUSTRATION	15
4.5	PARTS LIST	16
4.6	CLEAN-UP.....	17
4.7	DISASSEMBLY	17
4.7.a	Head Disassembly.....	17
4.7.b	Body Disassembly	18
4.8	ASSEMBLY	18
4.8.a	Pilot Valve (Both Heads)	18
4.8.b	Shuttle Assembly (Master Head).....	20
4.8.c	Quick Exhaust (Both Heads).....	20
4.8.d	Body Assembly.....	21
4.8.e	Final Assembly	21
4.9	TESTING	23
4.9.a	Performance Test	23
4.9.b	Dry Pump.....	22
4.9.c	Dry Suction	22
5	TROUBLESHOOTING	23
6	WARRANTY AND EXCLUSIONS	25
7	CONTACT INFORMATION	26
7.1	GENERAL CONTACT INFORMATION.....	26
7.2	TECHNICAL SUPPORT	26
7.3	REGIONAL REPRESENTATIVES	26

1 INSTALLATION

1.1 UNPACKING

After unpacking, the pump should be checked for any damage that may have occurred during shipment. Damage should be reported to the carrier immediately.

****Warning: Due to product weight (82 lb / 37 kg) always use two person lift when moving Mega 255 Chemical Pump**

The following items should be included within the shipping container:

<u>Qty</u>	<u>Item</u>	<u>Description</u>
1	255D	Mega 255D Pump
1	M255D	Operation/Maintenance Manual

1.2 TIE BOLT TORQUE

The tie bolts on the pump are tightened before leaving the factory. However, relaxation may occur due to handling, material creep, or other unforeseen events. Trebor recommends that all eight tie bolts be re-tightened upon pump install. The following procedure should be used.

1. Remove black tie bolt caps (Item 17 in 4.4 Parts Illustration) from both sides of all 8 tie bolts.
2. Apply 100 in-lbs. of torque to each slave side bolt while holding the master side bolt stationary. A star-pattern is advised.
 - a. The master side is the left side of the pump if you are looking at the fluid ports.
3. Replace tie bolt caps.

1.3 UTILITIES / HOOK-UP

The pump is mounted using four 3/8" bolts. It is recommended that the pump be mounted not more than 15° from level to maintain its self-priming ability and pumping efficiency.

Air Inlet: 1/2" FNPT (1/2" Dia. [12mm] supply tube minimum).

Air Supply: 25-80 psig (1.4 – 5.5 bar) clean dry air or nitrogen. (For Air Consumption, See Section 3.2 Performance Charts)

Fluid Ports: Inlet/Outlet Fluid Fittings and Surge Suppressor require torquing during pump installation. See Section 2.2 for hook- up diagram and torque values.

Remote Exhaust: 3/8" FNPT (Minimum 5/8" Dia. Tube)

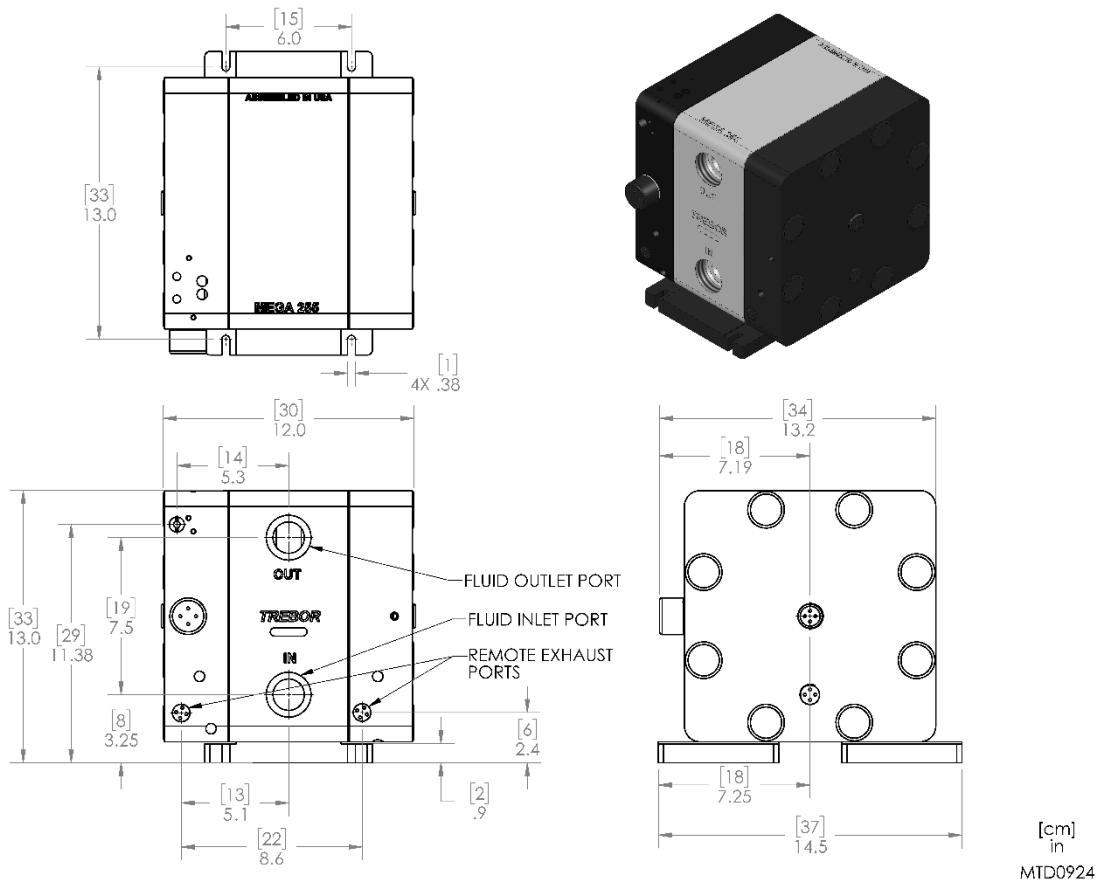

Figure 1-1

ATTENTION: The pump should be operated with clean, dry air or nitrogen. Particulate, water and oils in the air supply can damage the pump.

NOTE:

1. It is recommended that a filter be placed on the discharge side of the pump.
2. Although extensive efforts are made to deliver pumps to our customers completely dry, new pumps may contain residual moisture from their final DI water test.

Recommended Maximum Operating Levels:

Maximum supply CDA/N₂ pressure: 80 psig (5.5 bar)

Maximum fluid temperature: 212°F (100°C)

2 OPTIONS

2.1 FLUID PORT CONNECTION OPTIONS

NOTE: Use O-ring to seal stainless steel or other rigid plumbing.

Available Options

- A) PFA pipe stub out1" and 1 ½"
- B) NPT adapter nut1" and 1 ½"

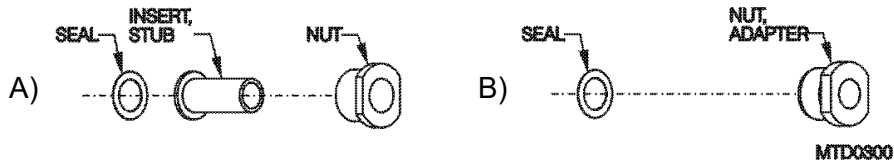

Figure 2-1

2.2 FLUID FITTINGS / SURGE SUPPRESSOR HOOK-UP

<u>Surge Suppressor</u>	<u>Assembled Height: IN (CM)</u>
SS95	17.82 (45.26)

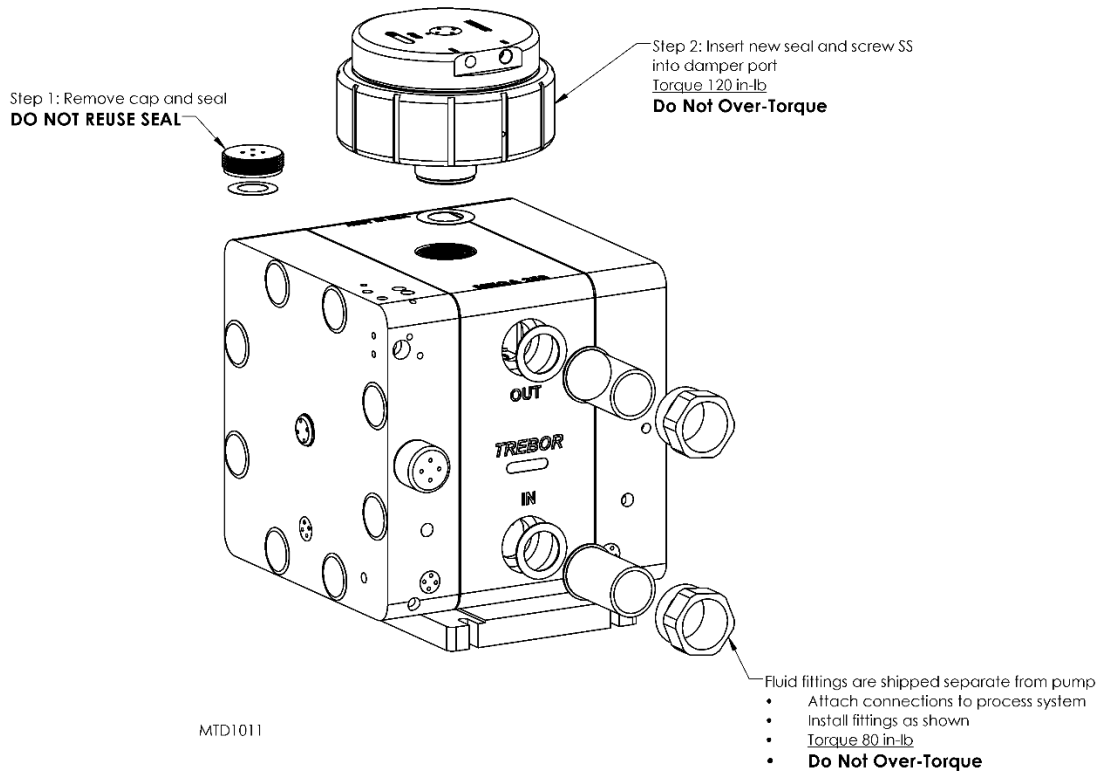
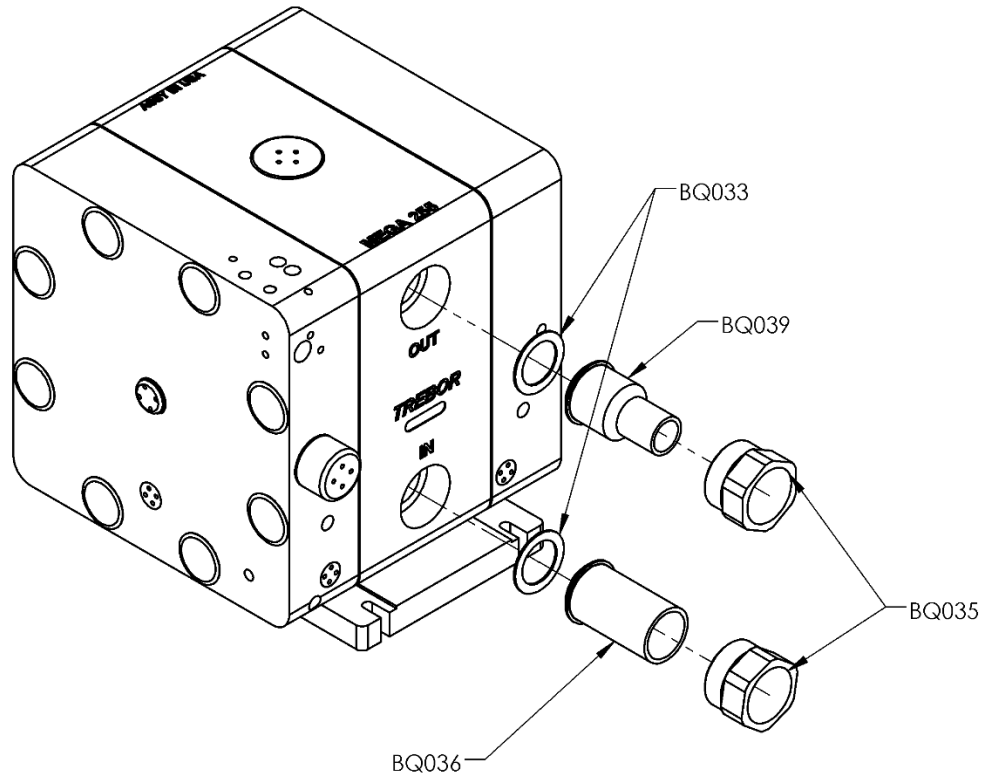

Figure 2-2

NOTE: See Surge Suppressor Operation Manual for detailed installation instructions.

255B16B24 Installation Instructions:

- Install seal (BQ033) in “IN” port
- Assemble BQ035 over BQ036 and install in “IN” port
- Torque nut to 80 in-lb
- Install seal (BQ033) in “OUT” port
- Assemble BQ035 over BQ039 and install in “OUT” port
- Torque nut to 80 in-lb



MTD1010

Figure 2-3

2.3 OPTIONAL LEAK SENSING

2.3.a Installation

- Remove plug and seal from port.
- Install probe assembly into leak sensor port. Probe is self-sealing and does not require a seal.
- Thread probe cap into port. (NOTE: **Do not over tighten**; damage to threads will occur.)

- Connect fiber optic cable to sensor (NOTE: Minimize bends in fiber optic cable to 2" radius minimum to help ensure optimum signal strength.). Fiber optic cable can be cut to desired length using the cable cutter provided.

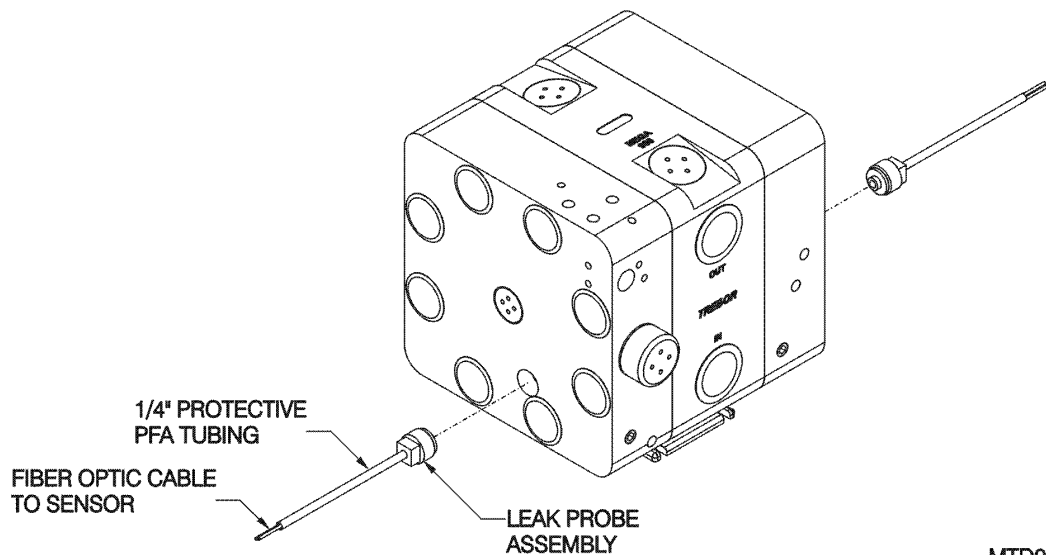

Figure 2-4

MTD0510

3 START-UP

- Pump air supply pressure should be regulated.
- Open the fluid suction (IN) line valve, if necessary.
- Open the fluid discharge (OUT) line valve, if necessary.
- Start with air regulator at low pressure setting. Increase or decrease setting to attain desired flow, up to 80 psig (5.5 bar). Minimum is 20 psig.
- Table 1: Consumption / Efficiency can be used to determine approximate air consumption.
- Refer to Troubleshooting, Section 5, if pump fails to start.

ATTENTION: Prolonged periods of dry running (greater than 5 minutes at a time) will damage critical internal pump parts.



CAUTION: When handling potentially dangerous fluids under pressure, the pump and its fittings should be placed in an enclosure.

3.1 HIGH TEMPERATURE OPERATION

Pump operation at temperatures above 60°C requires periodic tightening of the tie bolt nuts. The frequency of this procedure is best established by the user.

3.2 PERFORMANCE CHARTS

Pumping capacity is a function of air supply pressure and volume, suction head, suction line restrictions, discharge head, discharge line restriction, and fluid specific gravity and viscosity.

Air Supply Pressure (PSIG)	Discharge Fluid Pressure (PSIG)	Air Used (SCFM)	Flow (GPM)
20	0	15.0	44.1
20	10	11.0	28.3
30	0	21.0	54.4
30	20	17.0	32.5
40	0	26.0	58.7
40	20	23.0	38.6
40	30	20.0	45.2
50	0	30.0	62.9
50	20	29.0	45.2
50	40	25.0	27.5
60	0	37.0	65.3
60	20	34.0	48.9
60	40	30.0	34.6
60	50	29.0	27.5
70	0	43.0	68.2
70	20	41.0	51.5
70	40	35.0	37.3
70	60	31.0	23.8
80	0	46.0	68.4
80	20	44.0	52.3
80	40	40.0	38.6
80	60	35.0	26.7
80	70	31.0	19.6

Table 1: Consumption / Efficiency

NOTE: Specification to be used to size regulators and control valves.

MEGA 255 FLOW PERFORMANCE

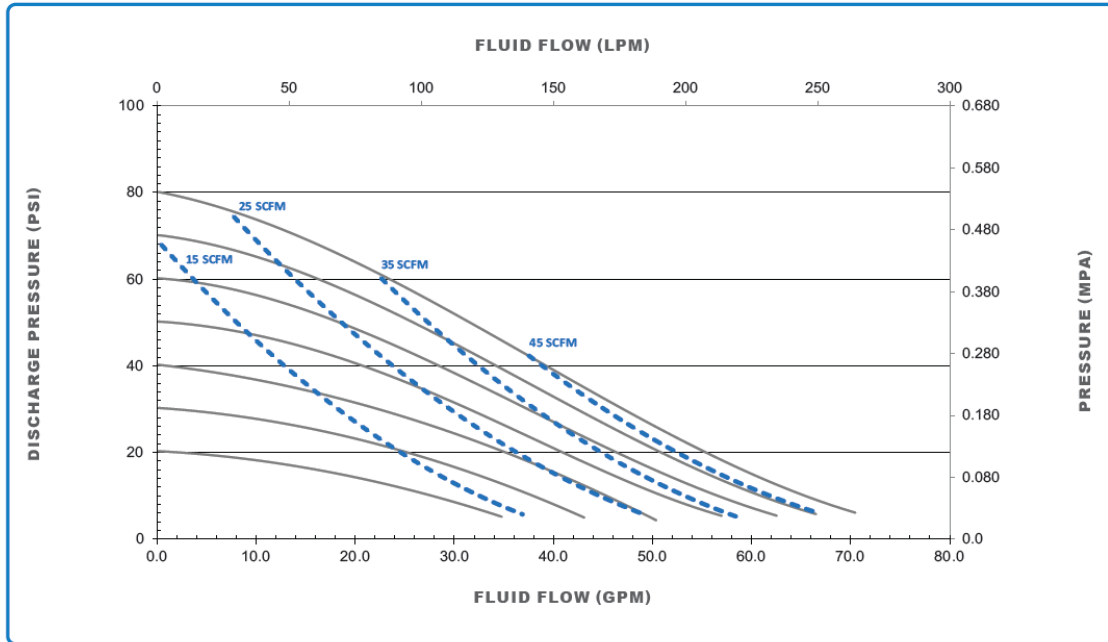

Pumps are tested in accordance with the Hydraulics Institute Standard of Testing.

Figure 3-1: Pressure & Capacity Chart

NOTE: Test information is based on specific conditions and limited sampling. Use for general reference only.

4 MAINTENANCE

Trebor pump maintenance can be divided into two categories: air system maintenance and fluid system maintenance. The purpose of air system maintenance is to prevent air system failures such as stalling or erratic cycling. The purpose of fluid system maintenance is to maintain suction and lift capabilities.

Pump Rebuild Service

Trebor International provides a factory rebuild service for customers using Trebor products. Trebor will rebuild any standard pump (exclusive of options). Please contact Trebor International Sales Department for current rebuild pricing. The fixed rebuild price includes a factory rebuild and parts equivalent to the standard rebuild kit. Each pump rebuilt by the Trebor factory receives a new one-year warranty. Repairs requiring more extensive part replacements will be quoted prior to proceeding with the pump rebuild. If the pump has exceeded its useful life and cannot be rebuilt, the customer may elect to purchase a new Trebor pump. If the customer chooses not to rebuild or replace the pump, a \$500.00 evaluation charge will be required.

All returned pumps are to be shipped freight prepaid with a valid Purchase Order for the cost of rebuild service. Please contact Trebor International prior to returning your pump to obtain an RMA Number and Pump Return Data Sheet to ensure proper safety precautions. Each pump will be evaluated and repaired within 5 working days of the receipt of pump at Trebor facility.

4.1 PREVENTIVE MAINTENANCE SCHEDULE

The following maintenance schedule is recommended to optimize pump performance and minimize failures. Tie bolt torque should be checked within 30 days of start-up and at periodic intervals thereafter. If the pump is subjected to thermal cycle operation, the tie bolt torque should be checked after the first 3 thermal cycles and periodically thereafter. Certain operating conditions that require more frequent maintenance intervals have been noted. In positive pressure inlet conditions where suction or lift is not required, fluid system maintenance may be extended. However, tie bolt retorque is still recommended.

Adhering to the recommended preventative maintenance schedule along with periodic inspection of the pump will ensure continued efficient operation and overall reliable pump performance.

It is recommended that the Preventive Maintenance Record (Section 4.1.a) be copied, maintained and kept with this unit for future reference.

MEGA 255D Maintenance Schedule

	Install	30 Days	3 Months	6 Months	9 Months	12 Months	15 Months	18 Months	21 Months	24 Months
Tie Bolt Torque (80 lb-in)	I			I		I		I		I
Pilot Buttons						I				
Shaft Bushing										R
Wear Discs										R
Main Shaft										R
Diaphragms and O-Ring Seals										R
Quick Exhaust Ports and Seals										R
Check Balls and O-Ring Seats										R
Exhaust Mufflers										R
Distribution Pilots										R
Tie Bolts										R
I=Inspect, R=Replace										

Note: If suction performance diminishes, inspect the shaft bushing.



4.1.a Preventive Maintenance Record

Company Name: _____

Company Address: _____

Product: _____ Serial Number: _____

Date: _____ Tech: _____ Notes: _____

Date: _____ Tech: _____ Notes: _____

Date: _____ Tech: _____ Notes: _____

Date: _____ Tech: _____ Notes: _____

Date: _____ Tech: _____ Notes: _____

Date: _____ Tech: _____ Notes: _____

Date: _____ Tech: _____ Notes: _____

Date: _____ Tech: _____ Notes: _____

Date: _____ Tech: _____ Notes: _____

Date: _____ Tech: _____ Notes: _____

Date: _____ Tech: _____ Notes: _____

Date: _____ Tech: _____ Notes: _____

Date: _____ Tech: _____ Notes: _____

Date: _____ Tech: _____ Notes: _____

Date: _____ Tech: _____ Notes: _____

Date: _____ Tech: _____ Notes: _____

Date: _____ Tech: _____ Notes: _____

Date: _____ Tech: _____ Notes: _____

Date: _____ Tech: _____ Notes: _____

Date: _____ Tech: _____ Notes: _____

Date: _____ Tech: _____ Notes: _____

Date: _____ Tech: _____ Notes: _____

Date: _____ Tech: _____ Notes: _____

Date: _____ Tech: _____ Notes: _____

4.2 RECOMMENDED SPARE PARTS

KR255D-00-A Spares Rebuild Kit, which includes:

<u>Part No</u>	<u>Qty</u>	<u>Description</u>	
KD255-00-A	1	Diaphragm Kit	
		Includes: (2) BQ029	Diaphragm Set
		(2) 98004440	O-Ring
KM255D-00-A	1	Maintenance Kit	
		Includes: (2) 98002987	Pilot Button
		(4) BQ026	Muffler Assembly
		(4) 98003047	Quick Exhaust Seal
		(4) 1900B0016	Quick Exhaust Port
98002303	4	Signal Tube O-Ring, Viton	
98004439	4	Transfer Tube O-ring, Viton	
98004441	4	O-Ring Seat, PTFE	
BQ003	4	Check Ball	
BQ008	1	Shaft Bushing	
BQ016	4	Wear Disc	
BQ022	2	Check Cap Seal	
BQ033	2	Fluid Port Seal	
BQ052	8	Tie-Bolt Assembly	
L0100	16	Tie Bolt Cap	

In critical applications, a spare pump is recommended to minimize potential down time.

4.3 TOOLS

The following tool kit is recommended as standard service equipment.

KT255-00-0 Mega 255 Tool Kit, which includes:

<u>Part No</u>	<u>Qty</u>	<u>Description</u>
T0228	1	5/16" Allen Key
98002136	2	7/16" Nut Driver
98002859	1	7/16" Socket
98003150	1	Tool Case
98003305	1	Drive Handle
T0226	1	Check Sleeve Insertion Tool
T0227	1	Check Sleeve Removal Tool
T0144	1	Cleaning Tool
T0146	1	3/4" Pin Tool
T0147	1	1" Pin Tool
T0148	1	1/2" Pin Tool
T0225	1	2 3/8" Pin Tool

4.4 PARTS ILLUSTRATION

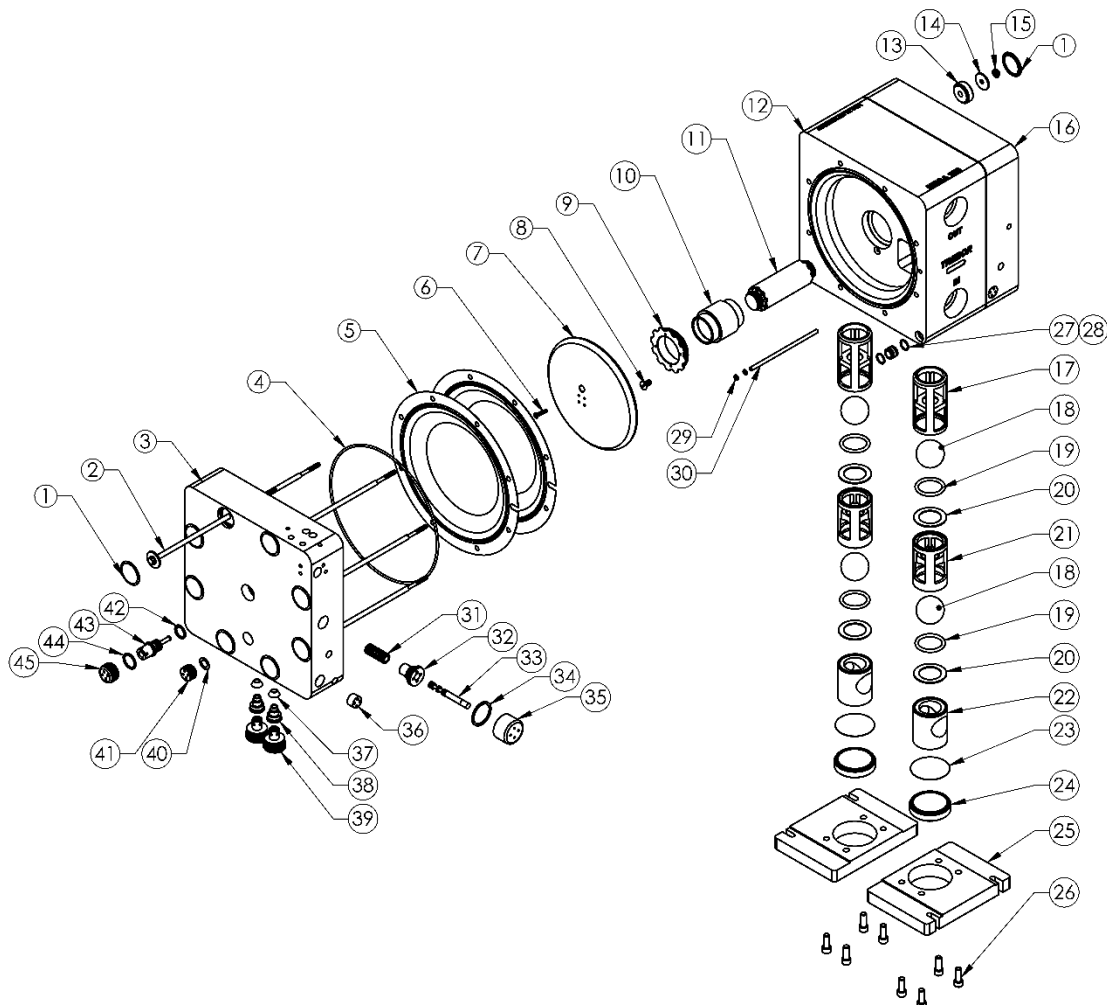

MTD0922



4.5 PARTS LIST

ILL NO	PART NO	QTY	DESCRIPTION	PM YEAR #	MATERIAL
1	L0100	16	Tie Bolt Cap		LDPE
2	BQ052	8	Tie Bolt Assembly	2	SS316, PFA
3	BQ001	1	Master Head		PP
4	98004440	2	Main Seal	2	Viton
5	BQ029	2	Diaphragm Set	2	PFA
6	98003769	2	Screw, Push Plate		PTFE
7	BQ009	2	Push Plate		PTFE
8	98003755	1	Screw, Locking Ring		PTFE
9	BQ010	1	Locking Ring		PTFE
10	BQ008	1	Shaft Bushing	2	PTFE
11	BQ007	1	Main Shaft	2	PFA
12	BQ002	1	Body		PTFE
13	L0140	8	Bushing		NPRM, EPDM
14	1900A0028-01	8	Tie Bolt Washer		SS316
15	98002341	8	Tie Bolt Nut		SS316
16	BQ006	1	Slave Head		PP
17	BQ004	2	Discharge Sleeve		PTFE
18	BQ003	4	Check Ball	2	PTFE
19	98004441	4	O-Ring Seat	2	PTFE
20	BQ016	4	Wear Disc	2	PTFE
21	BQ014	2	Suction Sleeve		PTFE
22	BQ005	2	Valve Stop		PTFE
23	BQ022	2	Check Bore Seal	2	PTFE
24	BQ021	2	Check Bore Cap		PTFE
25	BQ019	2	Pump Base		PP
26	98004535	8	Base Bolts		PP
27	98004439	4	Transfer Tube O-ring	2	Viton
28	BQ024	2	Transfer Tube		PP
29	98002303	4	Signal Tube O-ring	2	Viton
30	BQ018	1	Signal Tube		PFA
31	BQ050	1	Shuttle Sleeve Assembly		Ceramic, PTFE
32	L0105	1	Shuttle Adapter		PP
33	BQ044	1	Magnetic Spool Assembly		Ceramic, PEEK, NiCo
34	L0113	1	Shuttle Cap Seal		PTFE
35	BQ046	1	Magnetic Shuttle Cap		PP, NiCo
36	BQ023	2	Remote Exhaust Plug		PP
37	98003047	4	Quick Exhaust Seal	2	Viton
38	1900B0016	4	Quick Exhaust Port	2	UHMW
39	BQ026	4	Muffler Assembly	2	PP
40	L0167	2	Leak Detection Port Seal		PTFE
41	AM040	2	Leak Detection Port Plug		PP
42	W0117	2	Pilot Valve Seal		PTFE
43	BQ028	2	Pilot Valve	2	PEEK, PTFE, PPS, Viton
44	W0116	2	Pilot Cap Seal		PTFE
45	BQ015	2	Pilot Cap		PP

4.6 CLEAN-UP

To help remove potentially dangerous chemicals, the pump can be flushed with DI water or disassembled and thoroughly cleaned.

4.7 DISASSEMBLY

During the life of the pump it will be necessary to perform certain preventative maintenance procedures to ensure its continued high performance. This section and the next (4.8 Assembly) are provided for the user's convenience in disassembly and re-assembly in performing these procedures.

- Thoroughly clean/flush the pump using DI water (Refer to Section 4.6 Clean-Up).
- Remove tie bolt caps from the slave head.
- Remove nuts from the tie bolts (Slave Head side). Leave tie bolts in place.
- Lay the pump on its side with slave side up.
- Lift off the slave head.
- Remove the main seal and diaphragms.
- Remove the O-rings from the shuttle transfer tube.
- Remove the body assembly.
- Remove the second set of diaphragms and main seal.
- Remove the transfer tube and O-rings from the heads and body.
- Remove the remaining tie bolt caps and tie bolts.

NOTE: All polypropylene and fluoroplastic parts, when disassembled, should be thoroughly washed and be free from chemical residue for handling purposes.

4.7.a Head Disassembly

- Remove label cap (Slave Head only).
- Remove smart pilot cap from master and slave heads.
- Remove pilot valve and seals from Master and Slave Heads.
- Remove the shuttle cap and seal from the Master Head.
- Remove the shuttle spool assembly from the adapter detent.
- Remove Detent Adapter
- **Do not remove** the shuttle sleeve assembly from the shuttle bore.
- Remove the muffler spool and muffler pads from each head.
- Remove quick exhaust ports from heads.
- Remove quick exhaust seals.
- Remove remote exhaust plugs (if necessary).

4.7.b Body Disassembly

- Remove check bore caps using 3/4" pin tool and remove seals.
- Remove sleeves, balls, O-rings and check seat wear rings. Do not use excessive force.
- Unthread push plate locking screw and push plate from the one side of the shaft.
- Remove remaining shaft and push plate from body.
- Unthread second locking screw and push plate from shaft.
- Unthread shaft bushing locking screw from body.
- Using 2" pin tool, insert pins in shaft bushing locking ring located in the master head side of chamber and rotate CCW to remove bushing. Then push out bushing from the slave head chamber side.

4.8 ASSEMBLY

Prior to beginning assembly, inspect all parts to ensure they are clean and dry. Wear clean protective gloves.

4.8.a Pilot Valve (Both Heads)

NOTE: Do not use any tools to install the pilot button. Use of tools may damage the button.

- Remove existing pilot button and discard.
- Replacement pilot button should be tightened enough that the underside of the head touches the pilot piston.
- No light should be visible between the bottom of the button head and the piston.

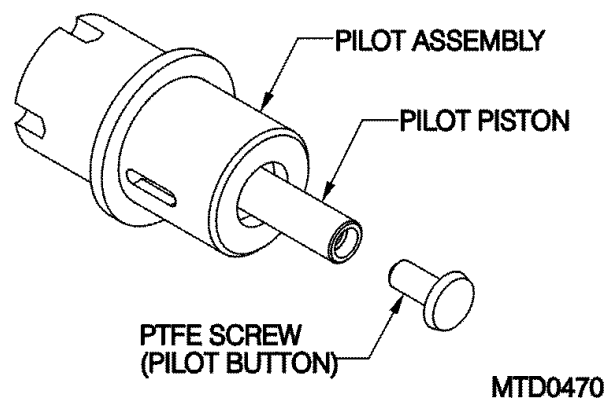
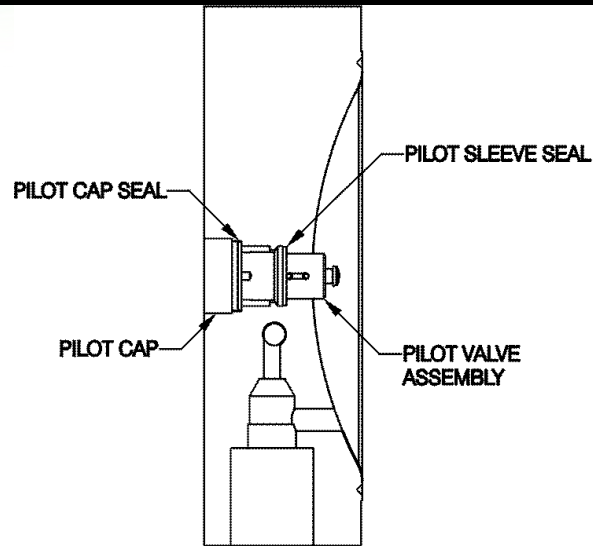

Figure 4-1

- Slide seal onto pilot valve body until even engagement with the shoulder is reached. The shoulder is located in the center of the pilot valve body.
- Thread the pilot valve assembly into the pilot bore of the head as shown in Figure 4-2. Tighten to 25 in-lbs. Do not over tighten.



MTD0311

Figure 4-2

- Install pilot cap seal.
- Thread pilot valve cap to engage seal. Tighten to 45 in-lbs.
- Repeat process for both heads
Install label cap (Slave Head only).

4.8.b Shuttle Assembly (Master Head)

NOTE: Ensure that the spool moves freely inside the sleeve prior to installation.

- Thread detent adapter into shuttle bore until flush against head. Tighten to 45 in-lbs.
- Insert shuttle spool assembly into shuttle adapter and shuttle sleeve. (Do not lubricate.)

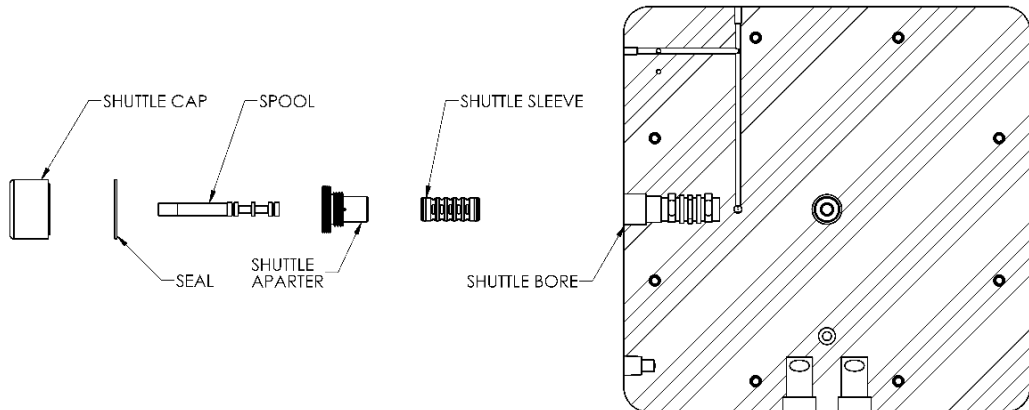

MTD0925

Figure 4-3

- Install the seal onto seal groove shoulder of the shuttle cap.
- Thread shuttle cap onto detent adapter. Tighten to 40 in-lbs.

ATTENTION: Threads should be snug. Do not over tighten.

4.8.c

Quick Exhaust (Both Heads)

- Insert quick exhaust seal.
- Insert quick exhaust port in each head as shown. Tighten to 15 in-lbs. Do not over tighten.

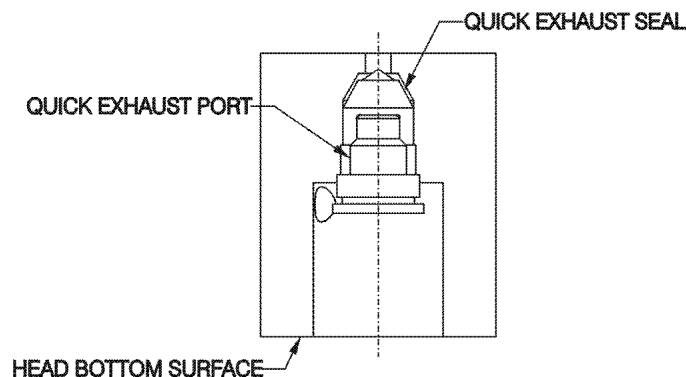

MTD0316

Figure 4-4

- Install 2 each muffler pads onto muffler spool and insert into exhaust port. Tighten to 40in-lbs.

4.8.d Body Assembly

NOTE: For easy installation, check sleeves that do not install easily (minimal effort) can be placed in a freezer prior to assembly to assist insertion. Body must be upside down with check port extending over a table edge so that parts remain assembled during insertion of sleeves (See **Error! Reference source not found..**)

- Insert discharge sleeve, check ball, O-ring and wear ring carefully into check bore. (Reference Parts Illustration)

NOTE: The suction sleeves are 3-3/8" (8.6 cm) long. The discharge sleeves are 4.16" (10.6cm) long.

- Repeat insertion process with the suction sleeve, check ball, O-ring and wear ring. (Reference Parts Illustration)
- Install valve stop ensuring that the open port in the valve stop faces the inlet port of the pump. (Reference Parts Illustration)
- Place seal and tighten check bore caps to 120 in-lbs.
- Repeat process for second check bore.

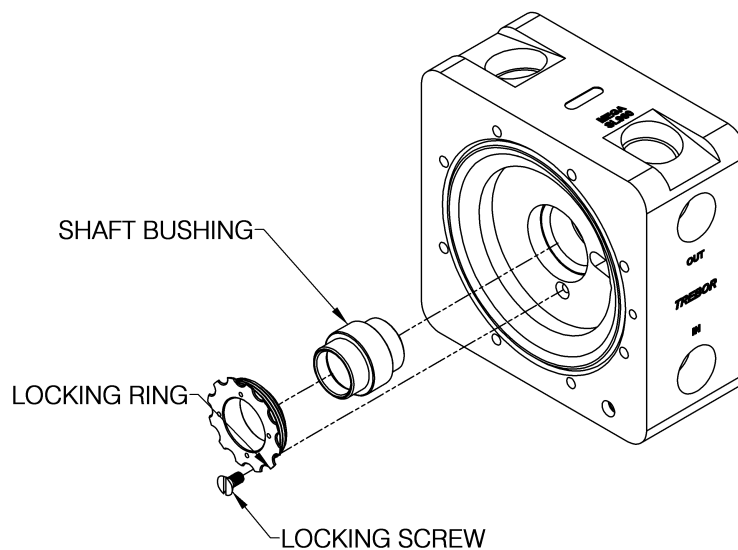

MTD0790

Figure 4-5

- Install shaft bushing per Figure 4-6.
- Install locking ring until flush with fluid cavity face and moderate resistance is achieved.
- Tighten until next available notch aligns with locking screw hole, check to ensure that the shaft bushing does not move.
- Insert locking screw into hole and tighten until flush with locking ring.
- Thread one push plate onto shaft until it bottoms out on shaft shoulder.

- Tighten push plate to 48 oz-in, and then rotate CW until locking screw hole is aligned with the next available notch in shaft. The first push plate can be visually aligned separate from the body.
- Install push plate locking screw. Tighten to 12 oz-in.

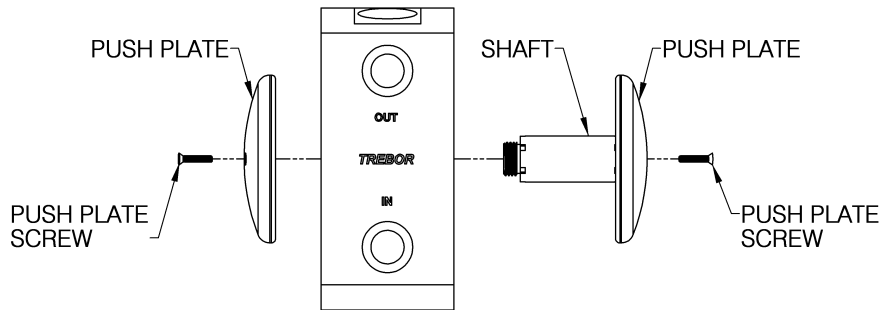

MTD0791

Figure 4-6

- Insert shaft through shaft bore as shown in figure 4-7.
- Thread on remaining push plate until push plate bottoms out on shaft shoulder.
- The second push plate cannot be visually aligned. Tighten push plate to 48 oz-in, then insert alignment pin into locking screw hole. Rotate push plate CW until locking screw hole is aligned with the next available hole in shaft and alignment pin drops into the shaft hole. Remove alignment pin.
- Install push plate locking screw. Tighten to 12 oz-in.

4.8.e Final Assembly

(See Section 4.4, Parts Illustration, for reference.)

- Insert tie bolts into master head (press fit) and lay head flat with tie bolts sticking up.
- Insert main transfer tube and O-ring into head.
- Install shuttle transfer tube with two O-rings.
- Place main seal into the main seal groove in master head.
- Install two diaphragms, removing all air from between diaphragms, onto the tie bolts and shuttle transfer tube. Note main seal groove alignment.
- Place body assembly onto tie bolts and master head, ensuring alignment of shuttle transfer tube and its corresponding body passage hole.
- Place remaining two diaphragms onto tie bolts, body and shuttle transfer tube. Note main seal groove alignment.
- Place two O-rings onto shuttle transfer tube.
- Place the main seal O-ring into the formed groove of the slave head.
- Place a second main transfer tube and O-ring into slave head.

- Lift the slave head and body, while maintaining compression of the main seal, flip the head and body over and insert the tie bolts into the master head. Ensure that the main seal of the master head is not dislodged.
- Place all bushings & flat washers onto tie bolt threaded ends.
- Install flange nuts onto tie bolts, tighten evenly in a star pattern (do not overload one side before applying torque to another as dislodgment of main seal can occur), final torque is 100 in-lbs.
- Snap in tie bolt caps.

4.9 TESTING

4.9.a Performance Test

- With the air supply at 0 psi open the air supply valve
- Increase the air pressure until the pump starts to cycle
- Record the start pressure, Target = <20psig
- Pump must prime once even cycling is achieved
- Increase pressure to 60 psi
- Check for fluid leaks, listen for air leaks, check for irregularity
- Close the discharge valve and deadhead for 2 minutes
- Pump must not experience jog, erratic cycling or leaks
- Open discharge valve and expel the remaining DI water
- Prepare the pump for drying

4.9.b Dry Pump

- Connect vacuum hose to discharge line
- Connect purge line to fluid inlet
- 60 psig Supply Pressure
- Purge pump by rotating pump side to side for 30 seconds.
- Allow the pump to additionally purge for 5 minutes.

4.9.c Dry Suction

- 20 psig Supply Pressure
- Record Suction Value
- Target = 14 in-Hg.

5 TROUBLESHOOTING

Pump Will Not Start, Fails to Operate

Cause:

Insufficient air pressure (must be enough to energize the pilot and shuttle valves).

Pilot valves 'buzzing'.

Insufficient air volume.

Dirty or damaged shuttle valve.

Damaged, sticky pilot valve (not following diaphragm properly).

Fluid discharge line blocked.
Downstream valve closed, filter plugged or other obstruction.

Solution:

There must be minimum 20 psig at pump air hook-up.

See Performance Charts (3.2) for requirements. Reference regulator and control valve capacity specifications.

Clean shuttle spool assembly and sleeve until free movement is assured (see 4.7.a,4.7.b), or replace.

Pilot valve piston must slide freely, full travel, in pilot valve sleeve.

Remove pilot pistons and check for debris or chemical attack.

Replace damaged valve assembly.

Remove obstruction.

Bubbles in Fluid Discharge

Cause:

Leaking fluid inlet fitting.

Leaking main seal.

Pump inlet line pressure reached saturation point (due to high suction requirement).

Ruptured (perforated) diaphragm.

Solution:

Tighten, or remove and wrap with TFE thread tape prior to tightening. Replace adapter O-ring.

Tighten tie bolt nuts to 100 in-lbs. Replace main seals if damaged.

Increase diameter of suction supply line (reduces restriction).

Reduce output flow.

Replace diaphragms.

Fluid Leaks

Cause:

Tie bolt torque not enough to effect seal.

Damaged main seal.

Check bore cap.

Ruptured diaphragm(s) can result in fluid leaks through air exhaust port.

Solution:

Tighten all nuts to 100 in-lbs.

Replace.

Check for irregularities in diaphragm groove on pump body.

Tighten, or remove and replace seal.

Replace diaphragms, and any parts that may have been damaged by fluid exposure.

Erratic Cycling

Cause:

Leaking detent cap.
Supply line restricted (cavitation).
Quick exhaust seal not seating.

Pilot valve not following diaphragm correctly.

Check ball(s) not seating.

Pilot transfer leak.

Solution:

Tighten and/or replace seal.

Reduce fluid restriction.

Check for particles between seal and port. Replace seal.

Pilot valve piston must slide freely, full travel in pilot valve sleeve.

Replace damaged pilot valve assembly.

Check O-rings for damage; replace if necessary.

Make sure check balls move freely in sleeves.

Tighten tie bolts to 100 in-lbs.

Replace transfer seals.



6 WARRANTY AND EXCLUSIONS

See the Trebor Standard Limited Warranty at
<https://www.treborintl.com/standard-limited-warranty/>



7 CONTACT INFORMATION

7.1 GENERAL CONTACT INFORMATION

Web: www.treborintl.com
Phone Number: (801) 561-0303
Toll Free Number: (800) 669-1303
Fax Number: (801) 565-1510
Email: treborinfo@idexcorp.com
treborsales@idexcorp.com
Address: Trebor International
8100 South 1300 West
West Jordan, Utah 84088 U.S.A.

7.2 TECHNICAL SUPPORT

Email: treborservice@idexcorp.com
Phone Number: (801) 561-0303

7.3 REGIONAL REPRESENTATIVES

Web: <http://www.treborintl.com/distributors>