

EVOLVE 55E PUMP

Operation / Maintenance Manual



CONTENTS

| | | |
|----------|--|-----------|
| 1 | INSTALLATION | 3 |
| 1.1 | UNPACKING | 3 |
| 1.2 | UTILITIES / CONNECTION | 3 |
| 1.3 | OPTIONAL END-OF-STROKE PROBE INSTALLATION..... | 5 |
| 1.4 | REMOTE EXHAUST CONNECTION | 5 |
| 2 | OPTIONS..... | 7 |
| 2.1 | FLUID PORT CONNECTION OPTIONS | 7 |
| 2.2 | FLUID FITTINGS / SURGE SUPPRESSOR CONNECTION | 7 |
| 2.3 | OPTIONAL LEAK SENSING..... | 8 |
| | 2.3.a Installation | 8 |
| | 2.3.b Sensor Signal Specifications | 8 |
| 3 | START-UP..... | 10 |
| 3.1 | PERFORMANCE CHARTS | 10 |
| 4 | MAINTENANCE | 12 |
| 4.1 | PREVENTIVE MAINTENANCE SCHEDULE | 12 |
| | 4.1.a Preventive Maintenance Record..... | 13 |
| 4.2 | RECOMMENDED SPARE PARTS..... | 14 |
| 4.3 | TOOLS | 14 |
| 4.4 | PARTS ILLUSTRATION | 15 |
| 4.5 | PARTS LIST | 16 |
| 4.6 | CLEAN-UP | 16 |
| 4.7 | DISASSEMBLY | 17 |
| | 4.7.a Head Removal | 17 |
| | 4.7.b Body Disassembly..... | 18 |
| | 4.7.c Control Base Disassembly..... | 18 |
| | 4.7.d Pump Cleaning..... | 18 |
| 4.8 | ASSEMBLY | 18 |
| | 4.8.a Control Base Assembly..... | 19 |
| | 4.8.b Body Assembly | 20 |
| | 4.8.c Head and Body Assembly..... | 21 |
| | 4.8.d Final Assembly..... | 21 |
| 4.9 | TESTING..... | 23 |
| | 4.9.a Performance Test..... | 23 |
| | 4.9.b Pump Drying Procedure..... | 23 |
| | 4.9.c Dry Suction Test..... | 23 |
| 5 | TROUBLESHOOTING | 24 |
| 6 | WARRANTY | 25 |
| 7 | CONTACT INFORMATION..... | 27 |
| 7.1 | GENERAL CONTACT INFORMATION | 27 |
| 7.2 | TECHNICAL SUPPORT | 27 |
| 7.3 | REGIONAL REPRESENTATIVES..... | 27 |

1 INSTALLATION

1.1 UNPACKING

After unpacking, the pump should be checked for any damage that may have occurred during shipment. Damage should be reported to the carrier immediately.

Although extensive efforts are made to deliver pumps to our customers completely dry, new pumps may contain residual moisture from their final DI water test.

The following items should be included within the shipping container:

| <u>Qty</u> | <u>Item</u> | <u>Description</u> |
|------------|-------------|--------------------|
| 1 | Pump | Evolve 55E Pump |

1.2 UTILITIES / CONNECTION

It is recommended that the pump be positioned within 15° from level to maintain self-priming ability and pumping efficiency. Allow sufficient room for tubing connectors. The pump mounts on a quick-change base for easy installation.

The pump has dual exhaust locations on the backside of the base. The exhaust locations require 1/2" (12mm) minimum clearance behind the control base. Care should be taken to elevate the pump whenever possible to help prevent flooding when the pump is located in a wet bench plenum. For remote exhaust connection, see Section 1.4.

Air Inlet: 1/4" FNPT (3/8" Dia. [8mm] supply tube minimum).

Air Supply: 20-100 psig (.14 - .69 MPa) clean dry air or nitrogen (see Performance Charts, Section 3.1).

Fluid Ports: Inlet/Outlet fluid fittings and surge suppressor require torquing during pump installation. See Section 2 for connection diagram and torque values.

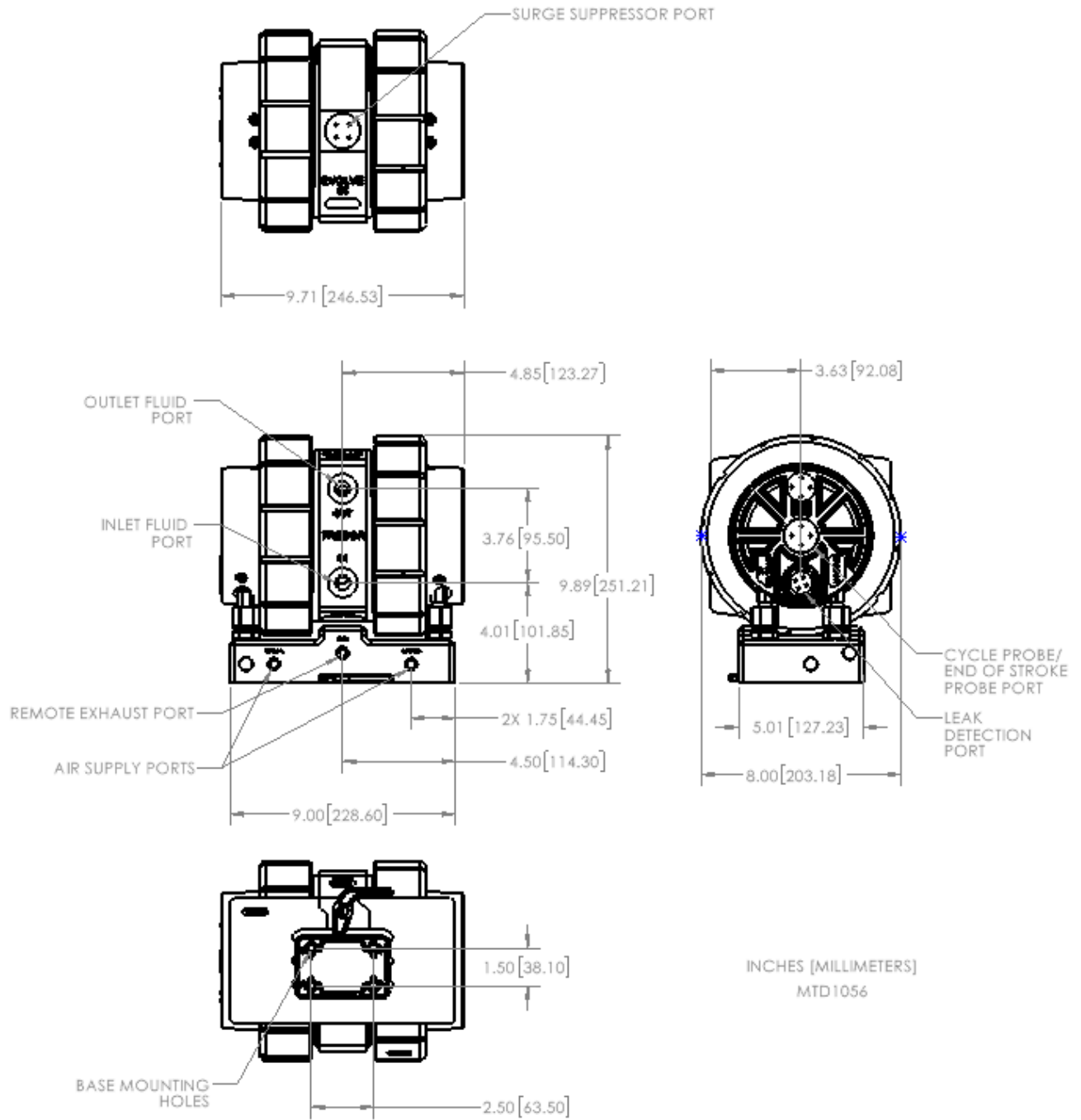

Figure 1-1: Dimensional Views

ATTENTION: The pump should be operated with clean, dry air or nitrogen. Particulate, water, and oils in the air supply can damage the pump.

NOTE:

It is recommended that a filter be placed on the discharge side of the pump.

1.3 OPTIONAL END-OF-STROKE PROBE INSTALLATION

Optic Cable: 1mm core; 1/4" PFA protective tubing.

Install seal into head.

Install probe assembly into head.

Thread probe cap into head hand tight only. No tool needed.

Connect fiber optic cable to sensor. NOTE: Minimize bends in fiber optic cable to 2" radius minimum to help ensure optimum signal strength.

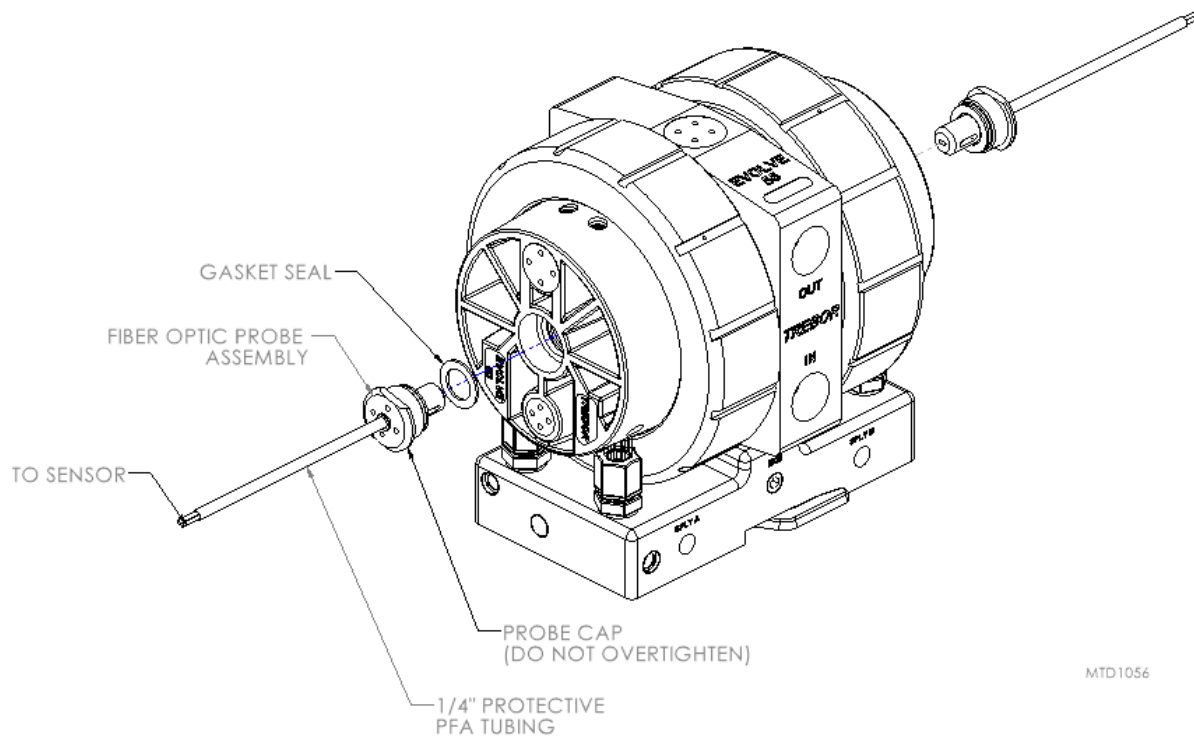

Figure 1-2: End-of-Stroke Sensor Installation

1.4 REMOTE EXHAUST CONNECTION

Some installations may benefit from remotely exhausting air from the pump to eliminate unwanted air turbulence or to prevent potentially damaging chemical vapors from entering the pump air cavities.

Remove existing Muffler Assemblies from the pump base.

Replace Muffler Assemblies with Exhaust Plug

Remove Pipe Plug (1/4" NPT) from the pump base. Install the appropriately sized fitting and tubing (not provided) to remote exhaust.

REAR VIEW

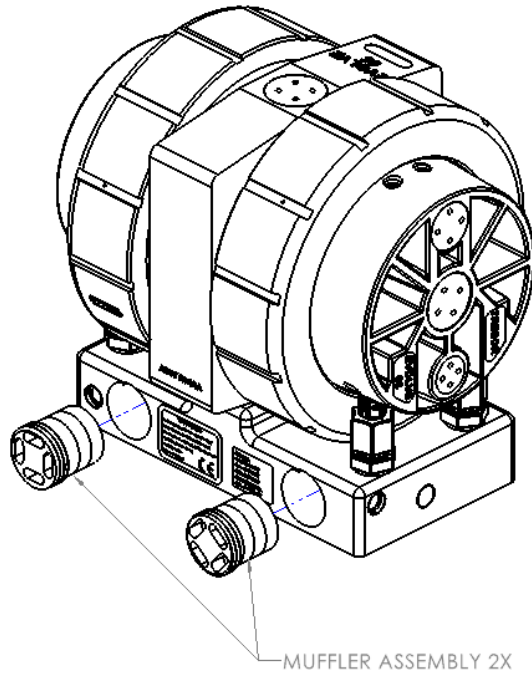

FRONT VIEW

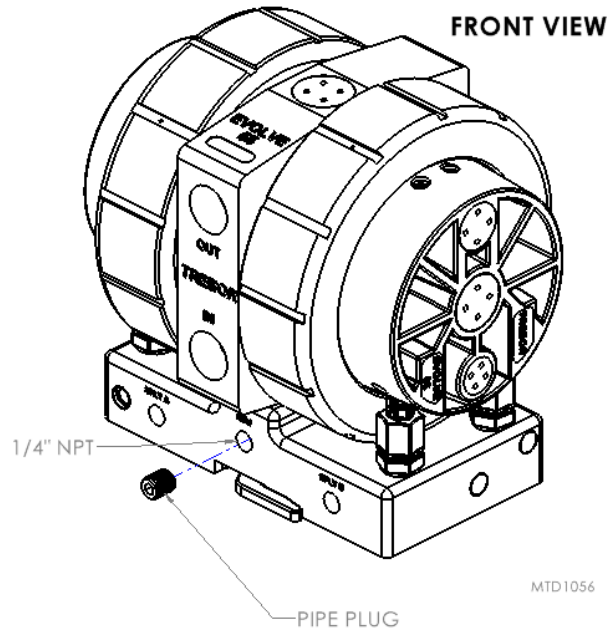

Figure 1-3: Remote Exhaust Connection

NOTE: To maintain optimum pump performance use 3/8" (8mm) tubing minimum at a length of 10 ft. (3 meters) maximum.

2 OPTIONS

2.1 FLUID PORT CONNECTION OPTIONS

NOTE:

1. Use O-ring to seal stainless steel or other rigid plumbing.
2. If torque is applied from the pump outward toward the Swagelok fitting, the resulting axial pressure can separate the seal from the gasket at the pump, which may lead to a leak.
3. PTFE tape is NOT designed to serve as a permanent sealing solution and may result in premature failure and potential leakage at the fluid port over time.

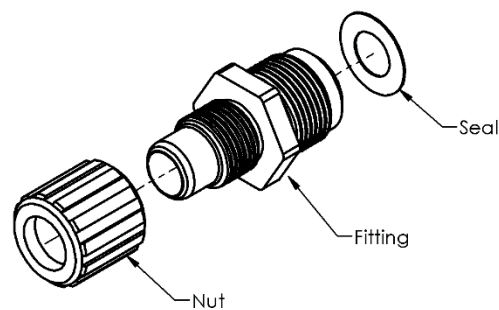

MTD0996

Figure 2-1: Fluid Port Adapters

Available Group Fittings:

- 3/4" Male Flare Connection (BK037)
- 1" Male Flare Connection (BK039)
- 3/4" Pipe Connection (G12000)
- 3/4" Tube Connection (AK157)
- 3/4" Pillar Connection (G12X12)
- 3/4" Female NPT Connection (AK159)

2.2 FLUID FITTINGS / SURGE SUPPRESSOR CONNECTION

| <u>Surge Suppressor</u> | <u>Assembled Height: mm (IN)</u> |
|-------------------------|----------------------------------|
| MODEL SS40 | 373 (14.7) |
| MODEL SS85 | 435 (17.1) |
| MODEL SS95 | 356 (14.0) |

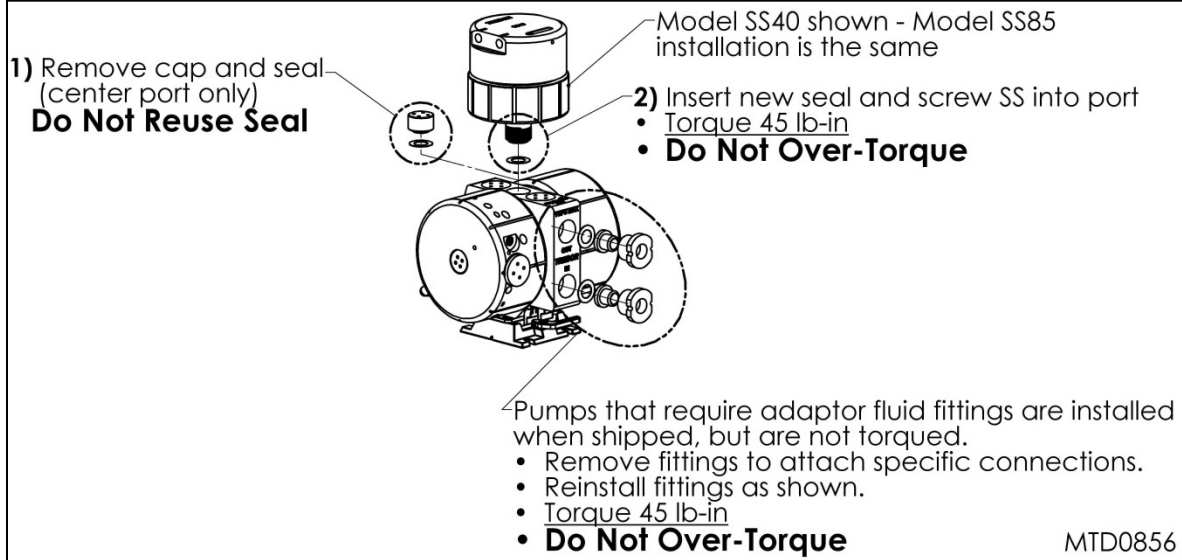

Figure 2-2: Generic Connection Diagram

NOTE: See Surge Suppressor Operation Manual for detailed installation instructions.

2.3 OPTIONAL LEAK SENSING

2.3.a Installation

Remove plug and seal from port. Probe is self-sealing.

Install probe assembly into leak sensor port.

Thread probe cap into port. (NOTE: Do not overtighten; damage to threads will occur.)

Push protective tubing into probe cap.

Connect fiber optic cable to sensor (NOTE: Minimize bends in fiber optic cable to 2" radius minimum to help ensure optimum signal strength.) Fiber optic cable can be cut to desired length using the cable cutter provided.

2.3.b Sensor Signal Specifications

The sensor signal is normally closed. In the event of a leak, no light signal is returned to the sensor.

NOTE: See your fiber optic sensor installation instructions for proper connection and adjustment.

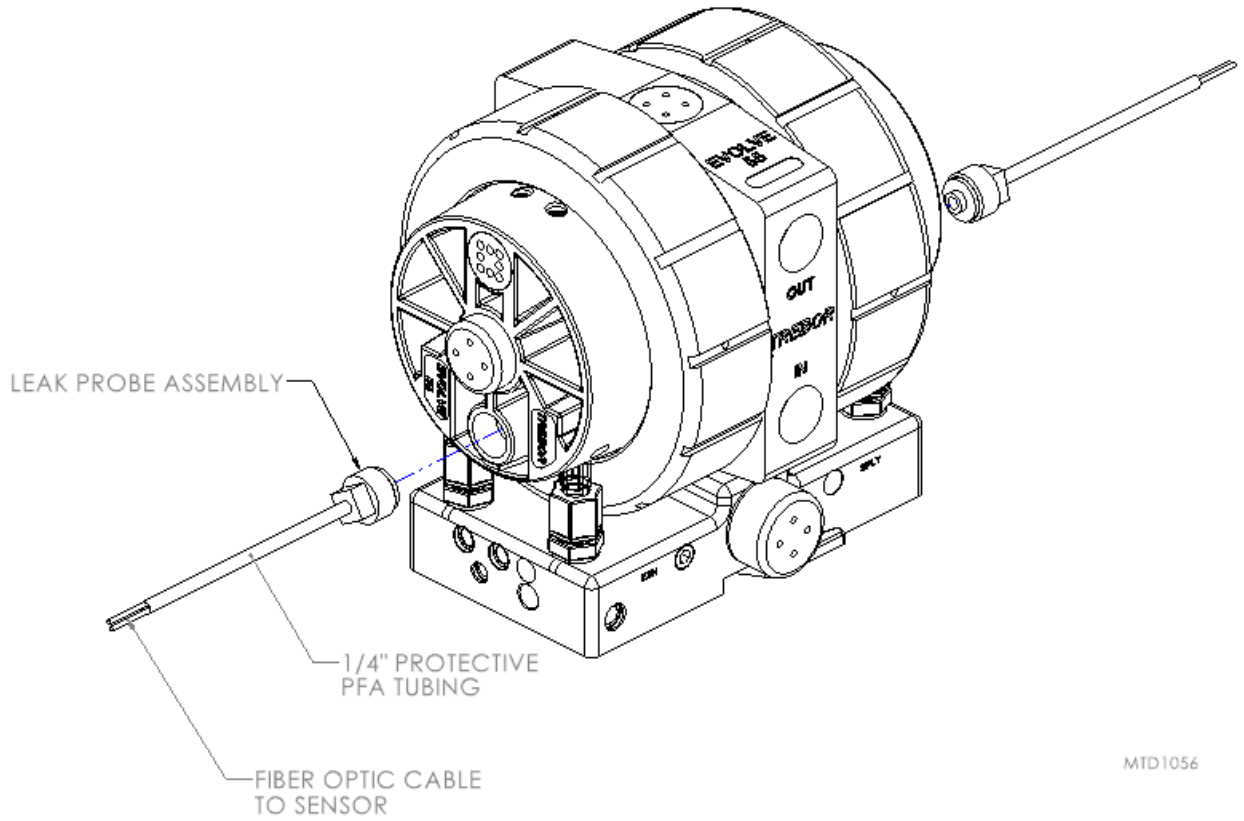

Figure 2-3: Leak Probe Assembly

3 START-UP

Pump air supply pressure must be regulated. (See Figure 3-2: Pressure vs. Fluid Temperature Chart).

Open the fluid suction (IN) line valve, if necessary.

Open the fluid discharge (OUT) line valve, if necessary.

Program external control to desired settings

Start slowly with air regulator at low (> 20 psi) pressure setting. Increase pressure to attain desired flow, up to the maximum rating (See Section 3.1).

Refer to Troubleshooting, Section 5, if pump fails to start.

ATTENTION: Prolonged periods (> 5 minutes) of dry running can damage critical internal pump parts.



CAUTION: When handling potentially dangerous fluids under pressure, the pump and its fittings should be placed in an enclosure away from operators.

3.1 PERFORMANCE CHARTS

Pumping capacity is a function of air supply pressure and volume, suction head, suction line restrictions, discharge head, discharge line restriction, and fluid specific gravity and viscosity.

NOTE: The following chart is for specifications to be used to size system.

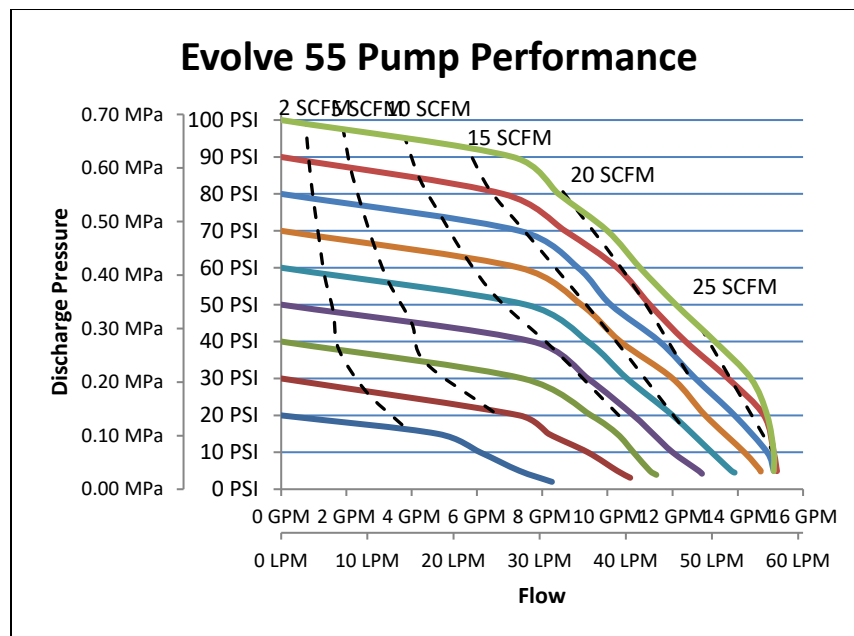
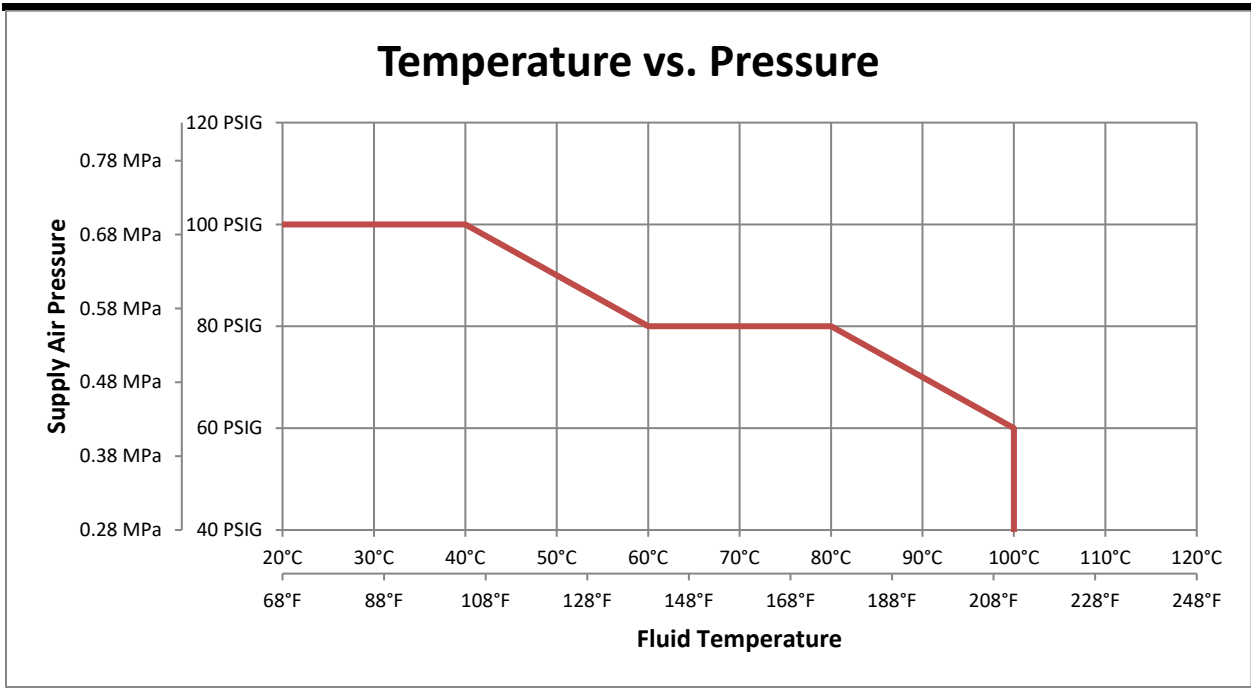

Figure 3-1: Pump Performance Curves with Air Consumption

NOTE: Test information is based on specific conditions and limited sampling. Use for general reference only.



**Figure 3-2: Pressure vs. Fluid Temperature Chart
 Recommended Maximum Pump Operating Levels**

NOTE:

1. The above graphs are not representative of all operating conditions – field application results may vary.
2. Be sure that fittings and tubing used are capable of these operating conditions.

Noise level while operating is approximately 80 dB

4 MAINTENANCE

Trebor pump maintenance can be divided into two categories: air system maintenance and fluid system maintenance. The purpose of air system maintenance is to prevent air system failures such as stalling or erratic cycling. The purpose of fluid system maintenance is to maintain suction and lift capabilities.

Pump Rebuild Service

Trebor International provides a factory rebuild service for customers using Trebor products. Trebor will rebuild any standard pump (exclusive of options). Please contact Trebor International Sales Department about current rebuild pricing. The fixed rebuild price includes a factory rebuild and parts equivalent to the standard rebuild kit. Each factory rebuild comes with a new one-year warranty. Repairs requiring more extensive part replacements will be quoted prior to proceeding with the pump rebuild. If the pump has exceeded its useful life and cannot be rebuilt, the customer may elect to purchase a new Trebor pump. If the customer chooses not to rebuild or replace the pump, an evaluation charge will be required.

All returned pumps are to be shipped freight prepaid with a valid Purchase Order for the cost of rebuild service. Please contact Trebor International prior to returning your pump to obtain an RMA Number and Pump Return Data Sheet to ensure proper safety precautions. Each pump will be evaluated and repaired within 5 working days of the receipt of pump at Trebor facility.

4.1 PREVENTIVE MAINTENANCE SCHEDULE

The following maintenance schedule is recommended to optimize pump performance and minimize failures. Certain operating conditions that require more frequent maintenance intervals have been noted. In positive pressure inlet conditions where suction or lift is not required, fluid system maintenance may be extended.

Adhering to the recommended preventative maintenance schedule along with periodic inspection of the pump will ensure continued efficient operation and overall reliable pump performance.

It is recommended that the Preventive Maintenance Record (Section 4.1.a) be copied, maintained, and kept with this unit for future reference.

EVOLVE 55E Maintenance Schedule

| | Install | 30 Days | 3 Months | 6 Months | 9 Months | 12 Months | 15 Months | 18 Months | 21 Months | 24 Months |
|--------------------------------|---------|---------|----------|----------|----------|-----------|-----------|-----------|-----------|-----------|
| Quick Exhaust Seal | | | | | | | | | | R |
| Muffler Media | | | | | | | | | | R |
| Shaft Seal and Shaft | | | | | | | | | | R |
| Check Balls and O-Rings | | | | | | | | | | R |
| Diaphragms | | | | | | | | | | R |
| Check Plug Seal | | | | | | | | | | R |
| Suction & Discharge Check Cage | | | | | | | | | | I |
| I=Inspect, R=Replace | | | | | | | | | | |



4.1.a Preventive Maintenance Record

Company Name: _____

Company Address: _____

Product: EVOLVE 55E Serial Number: _____

Date: _____ Tech: _____ Notes: _____

Date: _____ Tech: _____ Notes: _____

Date: _____ Tech: _____ Notes: _____

Date: _____ Tech: _____ Notes: _____

Date: _____ Tech: _____ Notes: _____

Date: _____ Tech: _____ Notes: _____

Date: _____ Tech: _____ Notes: _____

Date: _____ Tech: _____ Notes: _____

Date: _____ Tech: _____ Notes: _____

Date: _____ Tech: _____ Notes: _____

Date: _____ Tech: _____ Notes: _____

Date: _____ Tech: _____ Notes: _____

Date: _____ Tech: _____ Notes: _____

Date: _____ Tech: _____ Notes: _____

Date: _____ Tech: _____ Notes: _____

Date: _____ Tech: _____ Notes: _____

Date: _____ Tech: _____ Notes: _____

Date: _____ Tech: _____ Notes: _____

Date: _____ Tech: _____ Notes: _____

Date: _____ Tech: _____ Notes: _____

Date: _____ Tech: _____ Notes: _____

Date: _____ Tech: _____ Notes: _____

Date: _____ Tech: _____ Notes: _____

Date: _____ Tech: _____ Notes: _____

4.2 RECOMMENDED SPARE PARTS

KRE55E-00-A Spares Rebuild Kit, which includes:

| <u>Part No</u> | <u>Qty</u> | <u>Description</u> |
|----------------|------------|--|
| KME55E-00-A | 1 | Maintenance Kit Includes: (2) 98003047 Quick Exhaust Seal (2) 1900B0016 Quick Exhaust Port (2) AK205-01 Muffler Assembly |

| | | |
|-------------|---|---|
| KDE55E-00-A | 1 | Diaphragm Kit Includes: (4) BK019 Diaphragm (2) W0151 Fiber Optic Target |
|-------------|---|---|

| | | |
|----------|----|-----------------------------|
| 98001415 | 4 | PTFE Check Ball |
| 98002334 | 4 | PTFE O-ring |
| 98003079 | 2 | Shaft Seal |
| BK032 | 1 | Shaft |
| AK153 | 2 | Check Cap Seal |
| AM084 | 1 | Damper Port Seal |
| W0116 | 2 | Exhaust Port Gasket |
| AM020 | 2 | Top Pilot Port Gasket |
| AK120 | 2 | Bottom Pilot Port Gasket |
| AM037 | 2 | Leak Port Gasket |
| TJ006 | 16 | Diaphragm Retention Pin, PP |

4.3 TOOLS

The following tool kit is recommended as standard service equipment.

KTE55-00-A Tool Kit, which includes:

| <u>Part No</u> | <u>Qty</u> | <u>Description</u> |
|----------------|------------|---|
| 98003108 | 1 | Torque Wrench, 30-150 ft.-lbs., 1/2" Drive Handle |
| 98003150 | 1 | Tool Case, Large, Maxim, w/Foam |
| 98003305 | 1 | Drive Handle |
| 98003306 | 1 | Wrench, Adj., 15/16" |
| 98004281 | 1 | Tool Case, Large, w/Foam |
| T0126 | 1 | Tool, Shaft Insert |
| T0129 | 1 | Tool, Strap Wrench, Maxim |
| T0132 | 1 | Rebuild Fixture |
| T0144 | 1 | Tool, Wedge, Head Removal |
| T0146 | 1 | Tool, Pin, 3/4x1/4 Drive |
| T0147 | 1 | Tool, Pin, 1x1/4 Drive |
| T0148 | 1 | Tool, Pin, 1/2x1/4 Drive |
| T0149 | 1 | Tool, Pin, Optic Cap, 3/4 |
| T0175 | 1 | Diaphragm Pin Tool |

Optional:

| | | |
|----------|---|--|
| T0203 | 1 | Tool, Socket, Union Nut, M50 |
| T0203-01 | 1 | Tool, Socket, Union Nut, M50 (For use with pump attached to base.) |

4.4 PARTS ILLUSTRATION

BORDERS REPRESENT
 FLUID CONTACT AREAS OF PUMP

- - - - LINES REPRESENT POSITION OF
 PARTS WHEN ASSEMBLED

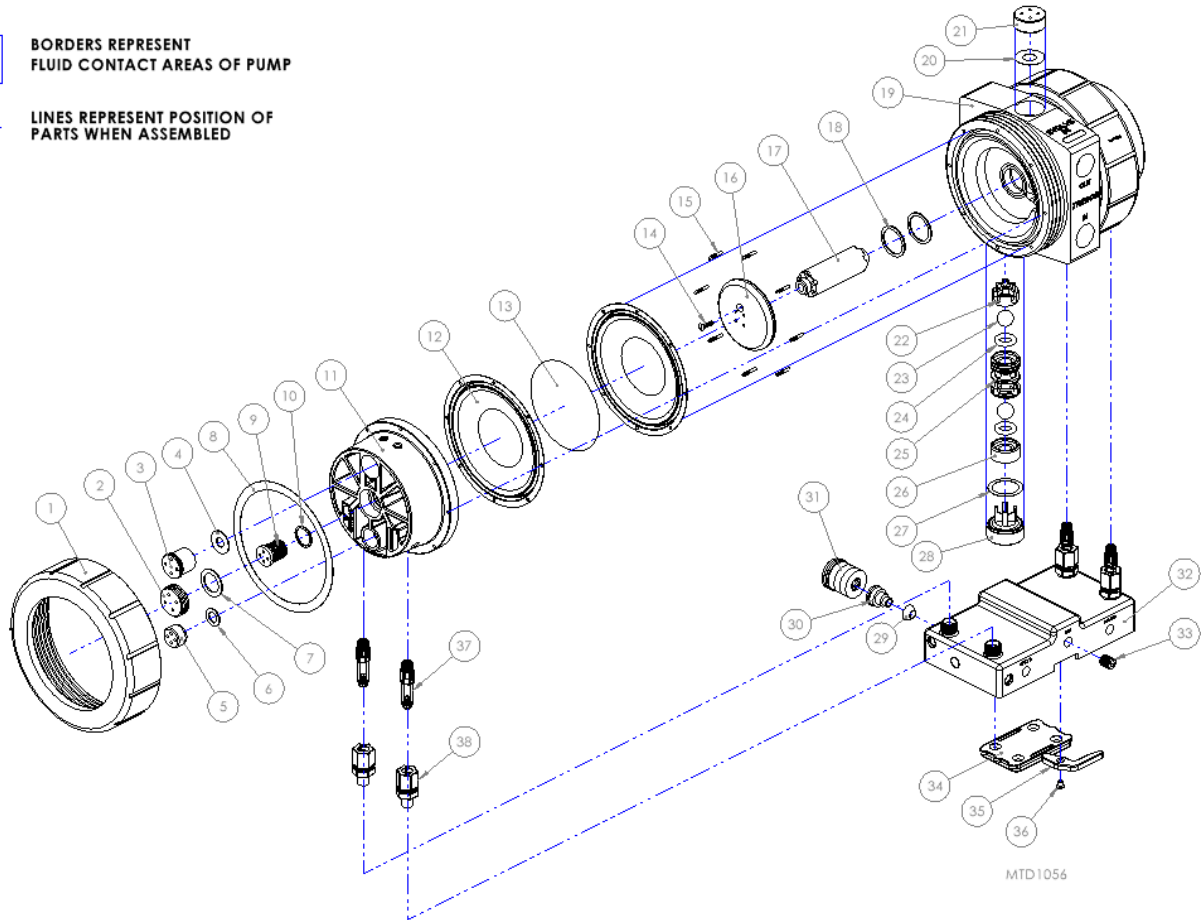

Figure 4-1: Evolve 55E Itemized Parts

4.5 PARTS LIST

| ILL NO | PART NO | QTY | DESCRIPTION | PM YEAR # | MATERIAL |
|--------|-----------|-----|-----------------------------|-----------|----------|
| 1 | AK003 | 2 | PP Union Nut (optional) | | PP |
| 1 | AK003-01 | 2 | PVDF Union Nut | | PVDF |
| 2 | BK026 | 2 | Top Pilot Port Plug | | PP |
| 3 | BK027 | 2 | Exhaust Port Plug | | PP |
| 4 | W0116 | 2 | Exhaust Port Gasket | | PTFE |
| 5 | AM035 | 2 | Leak Port Plug | | PP |
| 6 | AM037 | 2 | Leak Port Gasket | | PTFE |
| 7 | AM020 | 2 | Top Pilot Port Gasket | | PTFE |
| 8 | AK097 | 2 | PTFE Slip Ring | | PTFE |
| 9 | BK025 | 2 | Bottom Pilot Port Plug | | PP |
| 10 | AK120 | 2 | Bottom Pilot Port Gasket | | PTFE |
| 11 | BK004 | 2 | Pump Head | | PP |
| 12 | BK019 | 4 | Diaphragm | 2 | PTFE |
| 13 | W0151 | 2 | Fiber Optic Target | 2 | PTFE |
| 14 | 98003911 | 2 | Flathead Screw (#10-24X3/4) | | PTFE |
| 15 | TJ006 | 16 | Diaphragm Retention Pin | | PP |
| 16 | BK033 | 2 | Push Plate | | PTFE |
| 17 | BK032 | 1 | Shaft | 2 | PFA |
| 18 | 98003079 | 2 | Shaft Seal | 2 | PTFE |
| 19 | BK001 | 1 | Pump Body | | PTFE |
| 20 | AM084 | 1 | Damper Port Gasket | | PTFE |
| 21 | AM075 | 1 | Damper Port Plug | | PTFE |
| 22 | AK026 | 2 | Discharge Check Cage | | PTFE |
| 23 | 98001415 | 4 | Check Ball | 2 | PTFE |
| 24 | 98002334 | 4 | O-ring | 2 | PTFE |
| 25 | AK068 | 2 | Suction Check Cage | | PTFE |
| 26 | AK066 | 2 | Suction Check Seat | | PTFE |
| 27 | AK153 | 2 | Check Bore Gasket | 2 | PTFE |
| 28 | AK149 | 2 | Check Bore Plug | | PTFE |
| 29 | 98003047 | 2 | Quick Exhaust Seal | 1 & 2 | Viton |
| 30 | 1900B0016 | 2 | Quick Exhaust Port | 1 & 2 | UHMW |
| 31 | AK205-01 | 2 | Muffler Assembly | 1 & 2 | PP |
| 32 | BK028 | 1 | External Control Base | | PP |
| 33 | 98003080 | 1 | 1/4" NPT Plug | | PP |
| 34 | AK088 | 1 | Base Attachment Plate | | PP |
| 35 | AK108 | 1 | Lever | | PP |
| 36 | 98003071 | 1 | Lever Attachment Screw | | PP |
| 37 | AK182 | 4 | Transfer Tube | | PFA |
| 38 | 98003260 | 4 | Jaco Fitting | | PP |

4.6 CLEAN-UP

To help remove potentially dangerous chemicals prior to service or shipment, the pump should be flushed with DI water or disassembled and thoroughly cleaned. Allow DI water to flush through the inlet and out the outlet to prevent pressure build up.



CAUTION: When handling pump, wear appropriate personal protection gear, including safety glasses.

4.7 DISASSEMBLY

During the life of the pump, it will be necessary to perform certain preventative maintenance procedures to ensure its continued high performance. This section and the next (4.8 assembly) are provided for the user's convenience in disassembly and re-assembly procedures.

4.7.a Head Removal

- Loosen quick grip nuts on the transfer tubes from the Jaco fittings in the base using 13/16" open-end wrench.
- Remove pump assembly from the pump control base.
- Immerse or flush the pump assembly using DI water and a neutralizing agent.
- Install mounting fittings in pump fluid adapter ports and lock body into bench mounting fixture. **NOTE: Securely attach mounting fixture to work surface using hardware provided.**

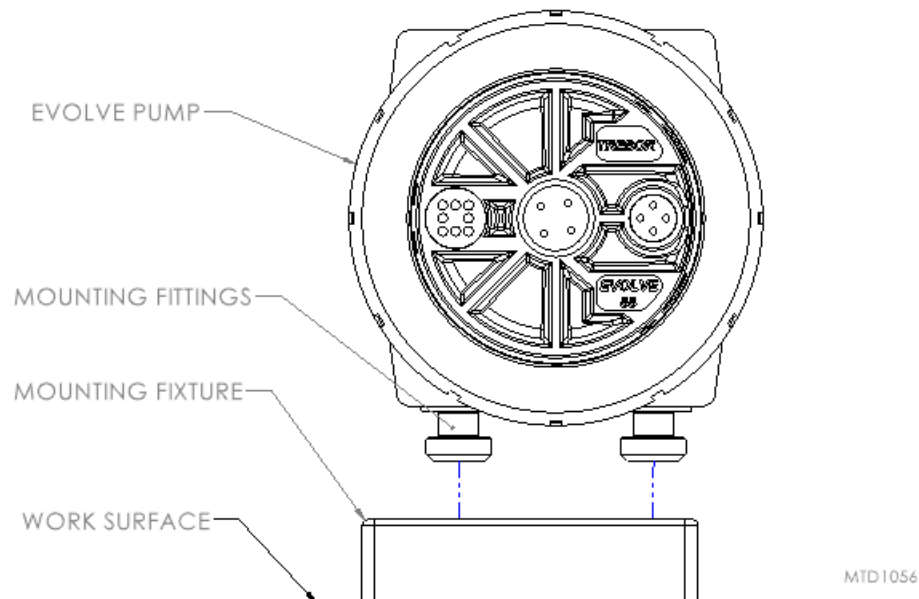

Figure 4-2: Pump and Mounting Fixture

- Remove the transfer tubes from pump heads (using latex gloves to assist grip).
- Remove the leak port plug and seal.
- Remove the top and bottom pilot plugs and seals.
- Remove the exhaust port plug and seal.
- Using the torque tool, turn the union nuts counterclockwise to remove.
- Remove head and check diaphragms for cracks or cuts.
- To remove diaphragms, slit diaphragm with a sharp knife and pull the diaphragms from the grooves. (Do not pry on diaphragm seal groove, as this will damage the sealing surface).



CAUTION: Following disassembly, parts should be thoroughly washed to be free from chemical residue for handling purposes.

4.7.b Body Disassembly

- Remove flat head screw from push plate.
- Unscrew push plate from the shaft in a counterclockwise direction. Pull other push plate and shaft from pump body.
- Remove suction plugs and seal on bottom of pump body using 1" pin tool.
- Remove suction seat using 1" pin tool.
- Remove ball and O-ring.
- Unscrew suction check using 1" pin tool turning it counterclockwise.
- Remove second set of O-rings and balls and pull-out discharge check cage.
- Remove shaft seals from pump shaft seal groove in the center of the shaft bore using the tip of a razor knife. Take care not to damage the shaft bore. NOTE: Do not reuse seals.
- Remove damper plug and seal using 3/4" pin tool.

4.7.c Control Base Disassembly

- Unlock control base from quick-change mount by pulling out lever on front of base to unlock mount. Then slide the base back until it stops. Lift base off mount.
- Using pH test strips evaluate whether base has any contamination in air passages, especially the muffler area. If present, neutralize using best methods prior to disassembly.
- Unscrew and loosen Jaco nut until transfer tubes can be removed. Do not remove the Jaco fitting from the base unless the fitting is damaged.
- Unscrew and remove muffler assemblies from base using the 1" pin tool.
- Remove the quick exhaust port using the 1/2" pin tool.
- Remove the quick exhaust seal. If needed, apply low-pressure air to each air supply port to aid in seal removal.

4.7.d Pump Cleaning

- Gently spray clean with DI water, or rinse by dunking all components in DI water, to remove any trace materials remaining after disassembly.

4.8 ASSEMBLY

Prior to beginning assembly, inspect all parts to ensure they are clean and dry. Wear clean protective gloves. Precautions should be exercised to prevent contaminating any of the air chamber surfaces with chemicals during handling.

4.8.a Control Base Assembly

- Perform these steps only if the Jaco fitting was removed during disassembly.
 - Inspect Jaco fittings for damage.
 - *If damaged, replace with black polypropylene Jaco Fittings (Jaco Part No. 10-8-4-P-PG. These parts can be ordered from Trebor or purchased separately).*
 - Apply PTFE thread tape to the NPT threads on the Jaco fittings.
 - Do not tape more than ½ of the threads.
 - Thread the fittings into pump base
 - Depth is .08 inch from bottom of wrench hex to top of pump base as shown. See Figure 4-3. Loosen the nut.

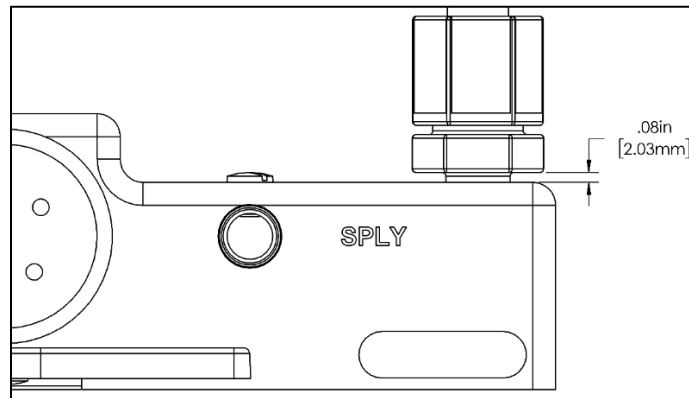

Figure 4-3: Jaco Fitting Final Position

- Insert the Quick Exhaust Seal into the bottom of the muffler port. See Figure 4-4.
- Thread the Quick Exhaust Port into the port. Torque to 20 in-lbs. using the 1/2" pin tool.

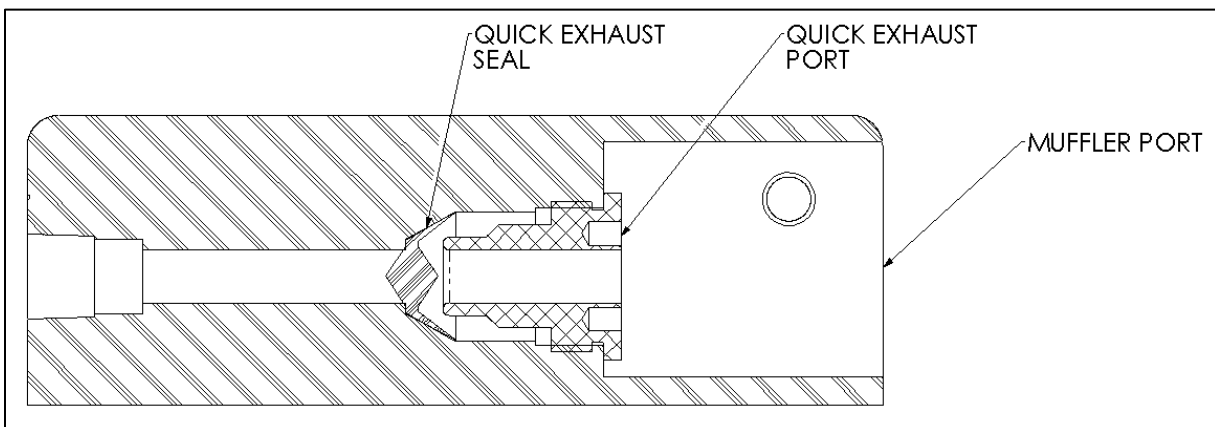

Figure 4-4: Quick Exhaust Port Assembly

- Thread muffler assemblies into base using 1" pin tool. Tighten until muffler assembly is flush with control base.

4.8.b Body Assembly

- Install seal and damper plug into body using 3/4" pin tool, torque to 50in-lbs.
- Remove pump from assembly fixture.
- Turn pump upside down to access check bores.
- Install discharge check cage into bore making sure small end fits into relief in bottom of bore.
- Drop ball into check cage, then O-ring.
- Install suction sleeve into the bore; tighten using 1" pin tool. Tighten until engagement with O-ring is achieved, then unthread the sleeve a quarter turn. Do not overtighten as damage may occur.
- Install second ball into check cage, then O-ring.
- Install suction seat using the 1" pin tool. Tighten until engagement with O-ring is achieved, then unthread the seat a quarter turn.
- Install check seal onto check bore shoulder and thread suction plug into bore using 1" pin tool, torque to 60in-lbs.
- Repeat for the second bore.
- Install two shaft seals in shaft bore groove with slits 180° apart.
- Thread one push plate onto shaft until push plate bottoms out on shaft shoulder.
- Tighten push plate to 48 oz-in, then rotate clockwise until locking screw hole is aligned with the next available hole in shaft. The first push plate can be visually aligned separate from the body.
- Install push plate locking screw. Tighten to 12 oz-in.
- Thread shaft onto shaft insert tool and insert shaft into bore. See Figure 4-5. This prevents damage to the TFE shaft seals and prevents dislodgement of shaft seals.

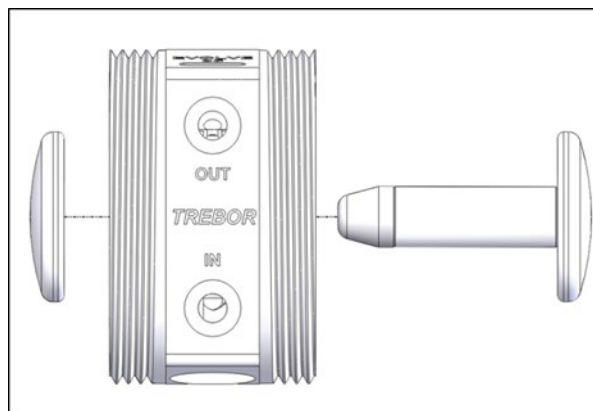

Figure 4-5: Shaft Insert Diagram with Tool

- Insert shaft through shaft bore as shown.
- Thread remaining push plate until push plate bottoms out on shaft shoulder.

- The second push plate, while in the pump body, cannot be visually aligned. Tighten push plate to 48 oz-in, then insert alignment pin into locking screw hole. Rotate push plate clockwise until locking screw hole is aligned with the next available hole in shaft and alignment pin drops into the shaft hole. Remove alignment pin.
- Install push plate locking screw. Tighten to 12 oz-in.

4.8.c Head and Body Assembly

- Install the mounting fittings in the pump fluid adapter ports.
- Thread union nut on one side hand tight. Do not install head or diaphragm at this point. This will protect body during initial pump assembly.
- Place pump body with the union nut on the table.
- Place one head on the table with the air chamber facing up.
- Insert 8 PP pins into the 8 small holes around the circumference of the main seal.
- Place the white fiber optic target between and centered between two diaphragms.
- Place the diaphragms onto the body, ensuring that the PP pins pass through all 8 holes in both diaphragms.
- While holding the diaphragms in place, lift the pump head and place it on the pump body. Ensure the transfer tube port openings are directed toward the bottom of the pump. Fit all 8 PP pins into the holes in the pump head.
- While holding the pump head in place, position the slip ring onto the pump head.
- Thread the union nut onto the pump body and tighten by hand.
- Turn the pump over and remove the union nut.
- Repeat the process of installing the diaphragms over the PP pins on the body and attach the head to the body with the second union nut.
- Using Strap Wrench (T0129) and the torque wrench (98003108), tighten the union nuts slowly to 107 ft.-lb. Repeat for the second union nut. (Torque includes strap wrench offset.) Torque range 95 to 118 ft.-lb.
- If using the optional T0203/T0203-01 M50 Union Nut Socket Tool, the torque is 140 ft.-lb with a range of 125 to 155 ft.-lb.

4.8.d Final Assembly

- For the following instructions, see Figure 4-6 for port locations and top/bottom alignments.
- Insert the Bottom Pilot Port Gasket into the center hole. Thread the Bottom Pilot Port Plug into the hole. Apply 35 in-lbs. with the pin tool.
- Insert the top pilot port gasket into the center hole. Thread the top pilot port plug into the hole. Apply 40 in-lbs. with pin tool.
- Insert Exhaust Port Gasket into the top hole. Thread the Exhaust Port Plug into the hole. Apply 35 in-lbs. with the pin tool.
- Place leak seal into leak port. Thread plug into leak port. Apply 35 in-lbs. torque.

- Thread transfer tube into head ports using Latex gloves for added grip. Ensure that the shoulder of the transfer tube touches the flat surface around the port hole.
- Repeat for second pump head.
- Place control base on mounting base. Slide base forward. Slide locking lever to secure base.
- Ensure that the quick grip nuts on the Jaco fittings are loosely attached.
- Carefully guide the transfer tubes into the Jaco fittings. Gently manipulate the pump until all four transfer tubes are fully seated in the Jaco fittings.
- Hand-tighten all four of the quick grip nuts. Then use a wrench to turn the nuts 1½ to 2 more turns to fully seal the fitting.
- Follow pump connection instructions above.

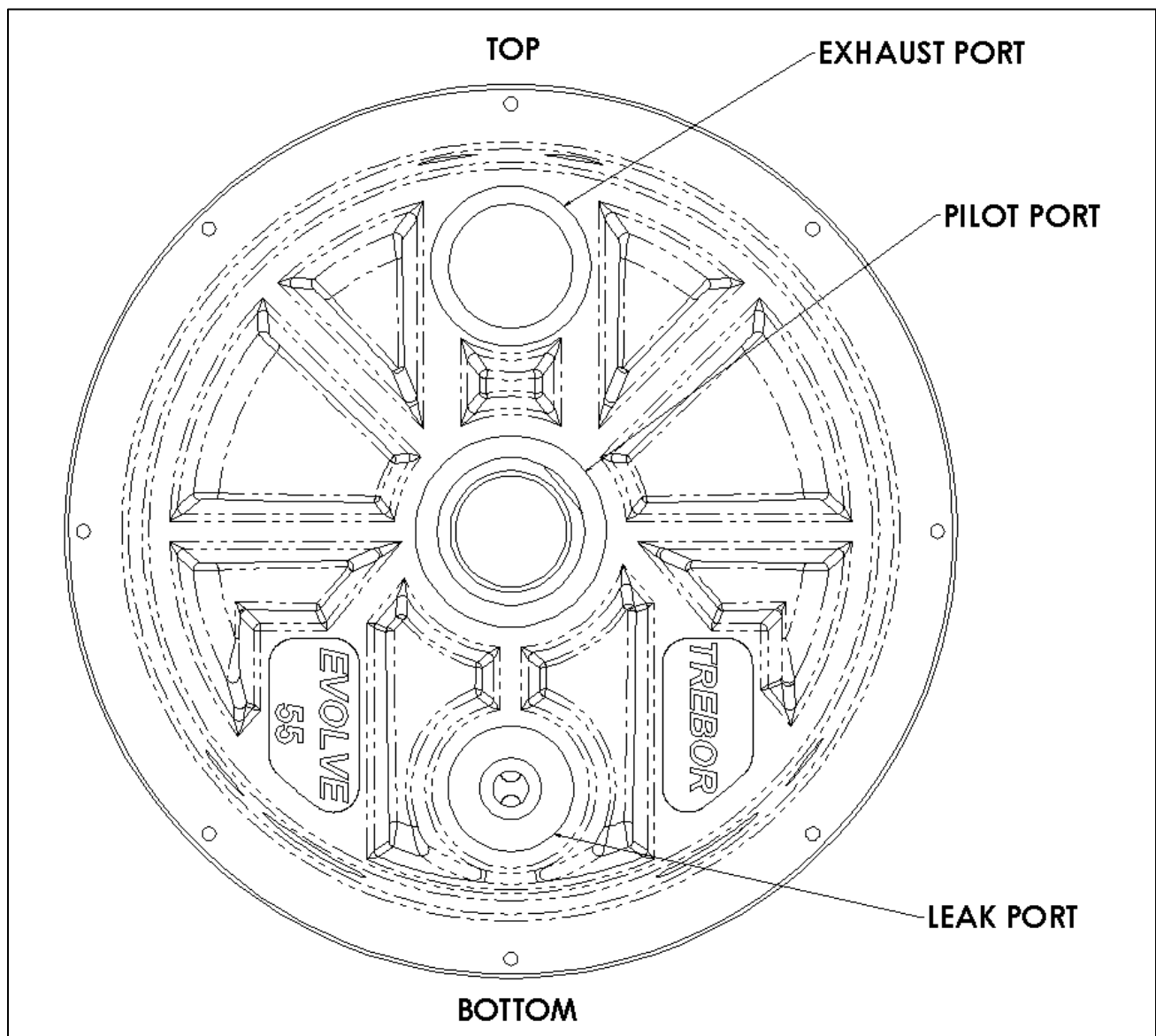

Figure 4-6: Port Location and Alignment of Pump Head

4.9 TESTING

4.9.a Performance Test

- Connect the pump to a fluid and air supply. See above instructions.
- With the air supply at 0 psi open the air supply valve.
- Increase the air pressure until the pump starts to cycle (Note: Pump cycling is controlled by the external control system. The pump will not operate without an operating external controller).
- Record the start pressure, Target = 28psig.
- Pump must prime and even cycling must be achieved before continuing.
- Increase pressure to 60 psi and allow pump to run for 5 minutes.
- Check for fluid leaks, listen for air leaks, and check for irregular operation.
- Close the air supply valve and disconnect the pump.
- If required, prepare the pump for drying.

4.9.b Pump Drying Procedure

- Connect vacuum hose to fluid discharge.
- Connect purge line to fluid inlet.
- Apply 60 psig air pressure to the fluid inlet.
- Cycle pump & vacuum dry by rotating pump side to side for 30 seconds.
- Turn off Air Supply and allow the pump to purge for 5 minutes.

4.9.c Dry Suction Test

- Connect to air supply. See above instructions.
- Connect a vacuum capable line with instrumentation to the pump fluid inlet.
- Apply 20 psig air pressure to the pump (Note: Pump cycling is controlled by the external control system. The pump will not operate without an operating external controller).
- Measure and record the suction value.
- Target = 12 in-Hg.

5 TROUBLESHOOTING

Pump Will Not Start, Fails to Operate

| <u>Cause:</u> | <u>Solution:</u> |
|--|---|
| <ul style="list-style-type: none"> Insufficient air pressure | <ul style="list-style-type: none"> Must be minimum 15 psi at pump air hook-up. |
| <ul style="list-style-type: none"> Air lines not attached properly | <ul style="list-style-type: none"> Check external controller. |
| <ul style="list-style-type: none"> Insufficient air volume (low supply pressure during running) | <ul style="list-style-type: none"> See Performance Charts (Figure 3-1) for requirements. Check both regulator and control valve capabilities. |
| <ul style="list-style-type: none"> Fluid discharge line blocked. Downstream valve closed, filter plugged or other obstruction | <ul style="list-style-type: none"> Remove obstruction. |
| <ul style="list-style-type: none"> Probe failure | <ul style="list-style-type: none"> Check fiber optic probes for correct operation. Check external controller. Check for excessive bends in fiber optic cable. Clean or trim fiber optic cable at the sensor. |

Bubbles in Fluid Discharge

| <u>Cause:</u> | <u>Solution:</u> |
|---|--|
| <ul style="list-style-type: none"> Leaking fluid inlet fitting | <ul style="list-style-type: none"> Replace adapter seal. |
| <ul style="list-style-type: none"> Leaking main seal | <ul style="list-style-type: none"> Tighten union nuts to 125 ft.-lbs. Replace diaphragms Check head & body seal grooves for nicks or scratches. |
| <ul style="list-style-type: none"> Pump inlet line pressure reached saturation point (due to high suction requirement) | <ul style="list-style-type: none"> Increase diameter of suction supply line (reduces restriction). Reduce output flow. |
| <ul style="list-style-type: none"> Ruptured (perforated) diaphragm | <ul style="list-style-type: none"> Replace diaphragms. |
| <ul style="list-style-type: none"> Check bore caps leaking | <ul style="list-style-type: none"> Tighten check bore caps Replace seals. |

Fluid Leaks

| <u>Cause:</u> | <u>Solution:</u> |
|---|---|
| <ul style="list-style-type: none"> Union nut torque low | <ul style="list-style-type: none"> Tighten union nuts to 125 ft.-lbs. |
| <ul style="list-style-type: none"> Leaking main seal | <ul style="list-style-type: none"> Replace diaphragms. Check head and body seal grooves for nicks or scratches. |
| <ul style="list-style-type: none"> Check bore cap | <ul style="list-style-type: none"> Tighten cap Remove and replace seal. |
| <ul style="list-style-type: none"> Ruptured diaphragm(s) | <ul style="list-style-type: none"> Replace diaphragms, and any parts that may have been damaged by fluid exposure. |

Erratic Cycling

| <u>Cause:</u> | <u>Solution:</u> |
|--|---|
| <ul style="list-style-type: none"> Air line or fittings leak in external controller | <ul style="list-style-type: none"> Replace tubing or tighten fittings. Replace controller. |
| <ul style="list-style-type: none"> Suction line restricted (cavitation) | <ul style="list-style-type: none"> Reduce fluid restriction. |
| <ul style="list-style-type: none"> Quick exhaust seal not sealing | <ul style="list-style-type: none"> Inspect for particles between seal and port. Replace seal. |
| <ul style="list-style-type: none"> Check ball(s) not seating | <ul style="list-style-type: none"> Inspect check assembly for damage; replace if necessary. Make sure check balls move freely in sleeves. |
| <ul style="list-style-type: none"> Transfer tube leaking | <ul style="list-style-type: none"> Tighten transfer tubes and quick grip nuts as described in Section 4.8.a. |

6 WARRANTY



EVOLVE 55 PUMP

Trebor International, Inc. (“Trebor”) warrants to the original end-use purchaser that no product sold by Trebor that bears a Trebor brand* (“Trebor Product”) shall fail under normal use and service due to a defect in material or workmanship for **24 months** from date of shipment from Trebor’s factory.

If Trebor determines that Trebor Product has failed under normal use and service due to a defect in material or workmanship within the warranty period for such Trebor Product, Trebor will repair or replace such Trebor Product at no charge to the original end-use purchaser. The determination to repair or replace shall be made by Trebor in its sole discretion. The repaired or replacement Trebor Product shall be shipped to the original end-user purchaser freight collect unless the original end-user purchaser makes other arrangements for shipment. The original end-user purchaser shall bear all risk of loss or damage during shipment. Repaired and replacement Trebor Product shall be warranted only for the remainder of the original warranty period.

The above warranty and repair or replacement obligation does not apply if: (i) a Trebor Product is altered, changed, modified or tampered with in any way, other than an alteration, change or modification made by or with the authorization of Trebor, (ii) a Trebor Product is damaged after deposit with the carrier for shipment, (iii) a Trebor Product is not used and maintained in accordance with Trebor’s recommended operating and maintenance manuals, instructions and procedures, (iv) a Trebor Product is not properly incorporated or installed in, or not properly combined with, another product, component or part with which such Trebor Product is used (“Other Product”), (v) the failure or substandard performance of a Trebor Product is directly or indirectly attributable to, or directly or indirectly results from or arises out of, the failure or substandard performance of an Other Product, (vi) the failure or substandard performance of a Trebor Product is directly or indirectly attributable to, or directly or indirectly results from or arises out of, compliance with any design, specification or requirement of the original end-use purchaser, (vii) a Trebor Product is used in a manner, with a substance or for a purpose

other than the normal manner, substance and purpose for which it is intended or is otherwise subjected to abnormal use or service, (viii) a Trebor Product is subjected to a power surge, brown out or other similar occurrence, or (ix) the failure or substandard performance of a Trebor Product is directly or indirectly attributable to, or directly or indirectly results from or arises out of, normal wear and tear of the Trebor Product (including, without limitation, things such as worn seals, clogged passages or valves, damage due to corrosive, insoluble, or abrasive substances, etc.).

To be eligible for warranty repair or replacement, the original end-use purchaser must notify Trebor of the Trebor Product failure in writing within the warranty period for such Trebor Product and, if requested by Trebor, the product must be promptly returned for inspection and evaluation, freight prepaid, to either Trebor’s factory at 8100 South 1300 West, West Jordan, Utah 84088 or to a Trebor authorized distributor.



The original end-user purchaser must also promptly provide Trebor or its authorized distributor with all such information as either of them may request concerning the maintenance, operation, use and failure of any Trebor Product that is claimed to have failed due to a defect in material or workmanship. Return of a Trebor Product to Trebor's factory requires a Return Material Authorization (RMA) from Trebor, and the RMA number must be included with the returned Trebor Product. The original end-user purchaser shall bear all risk of loss or damage during shipment.

THE ABOVE WARRANTY, RIGHTS AND REMEDIES ARE THE SOLE AND EXCLUSIVE WARRANTY, RIGHTS AND REMEDIES PROVIDED BY TREBOR TO ANY PURCHASER OR USER OF ANY PRODUCT AND ARE IN LIEU OF ALL OTHER WARRANTIES, RIGHTS AND REMEDIES, EXPRESS, STATUTORY OR IMPLIED, AND TREBOR DISCLAIMS ALL OTHER WARRANTIES, RIGHTS AND REMEDIES, EXPRESS, STATUTORY OR IMPLIED, IN RELATION TO ANY PRODUCTS, INCLUDING, WITHOUT LIMITATION, ANY IMPLIED WARRANTIES WITH RESPECT TO MERCHANTABILITY, FITNESS FOR ANY PARTICULAR PURPOSE, COMPATIBILITY OR INTEROPERABILITY WITH OTHER PRODUCTS, ACCURACY, PERFORMANCE AND NON-INFRINGEMENT, AND ANY WARRANTIES ARISING FROM ANY COURSE OF DEALING, USAGE OR TRADE PRACTICE. EXCEPT FOR THE ABOVE LIABILITIES AND OBLIGATIONS, TREBOR SHALL HAVE NO LIABILITY OR OBLIGATION TO ANY PURCHASER OR USER OF ANY PRODUCT IN CONNECTION WITH THE FAILURE, IMPROPER PERFORMANCE, MALFUNCTION, INACCURACY OR NON-CONFORMANCE OF, OR ANY DEFECT OR DEFICIENCY IN, ANY PRODUCT.

Under no circumstances shall Trebor have (i) any liability for any claim, loss, damage, injury, liability, obligation, cost or expense that directly or indirectly relates to or arises out of the use or failure of any product or (ii) any liability for any penalties or any indirect, consequential, incidental, special, punitive or reliance damages, including, without limitation, lost or unrealized sales, revenues, profits, income, cost savings or business, lost or unrealized contracts, loss of goodwill, damage to reputation, loss of property, loss of material being processed, loss of information or data, loss of production, downtime, or increased costs, even if Trebor is advised or placed on notice of the possibility of such damages and notwithstanding the failure of any essential purpose of any product.

Statements and data relating to products on Trebor's website and in Trebor's promotional, marketing and technical literature and materials are not warranties. Purchasers and users of products have the sole responsibility for determining the suitability of products for specific uses and applications.

Trebor makes no warranty with respect to product that does not bear a Trebor brand ("Non-Trebor Products"). Any warranty with respect to Non-Trebor products is limited to a pass through of the manufacturer's warranty to the extent permitted or authorized by the manufacturer.

In any event, Trebor's total liability to any purchaser or user of any product shall limited to the original price paid to Trebor for such product.

No Trebor distributor or other person is authorized to modify this Standard Limited Warranty or impose any liability or obligation on Trebor other than expressly provided herein.

7 CONTACT INFORMATION

7.1 GENERAL CONTACT INFORMATION

Web: www.treborintl.com
Phone Number: (801) 561-0303
Toll Free Number: (800) 669-1303
Fax Number: (801) 255-2312
Email: treborinfo@idexcorp.com
treborsales@idexcorp.com
Address: Trebor International
8100 South 1300 West
West Jordan, Utah 84088 U.S.A.

7.2 TECHNICAL SUPPORT

Email: treborservice@idexcorp.com
Phone Number: (801) 244-6156

7.3 REGIONAL REPRESENTATIVES

Web: http://www.treborintl.com/about_contact_us.asp#